

ISSUED FOR SPA
2024-01-11
REISSUED FOR SPA
2024-07-11

RON KOUZES
LANDSCAPE ARCHITECTS

388 Queen Street East, London, Ontario, N6A 1Y7

Schlegel Village - Oakville

2150 WILLIAM HALTON PARKWAY W. OAKVILLE ONTARIO

Project No.: 22-237s
Drawn By: MCB
Plot Date: 2024-07-12

Schlegel Villages

LANDSCAPE PLAN

LANDSCAPE PLAN

SCALE = 1:400

KEY	COMMON NAME	BOTANICAL NAME	QTY	SIZE	COND
Ar	RED MAPLE	<i>Acer rubrum</i> 'Sunset'	1	60cmcl	UB
A6	SUGAR MAPLE	<i>Acer saccharum</i>	6	60cmcl	UB
Bu	GREEN GBT BOXWOOD	<i>Buxus microphylla</i> 'Green Gem'	40	30cm	POT
Cc	MULTI-STEM REDBUD	<i>Cercis canadensis</i> multi-stem	2	250cm	POT
Cc1	SINGLE-STEM FOREST PANSY REDBUD	<i>Cercis canadensis</i> single-stem Forest Pansy	6	45cmcl	UB
Cc2	HACKBERRY TREE	<i>Celtis occidentalis</i>	5	60cmcl	UB
D1	PARDON ME DATILYLLY	<i>Hemerocallis</i> 'Pardon Me'	146	2 1/2gal	POT
Ge	HAIRY VIOLET	<i>Viola blanda</i>	6	60cmcl	UB
Ge	ROZANE GERANIUM	<i>Geranium</i> 'Rozanne'	148	2 1/2gal	POT
Gt	SHADEMASTER LOCUST	<i>Gleditsia triacanthos</i> 'Shademaster'	10	60cmcl	UB
Hb	BIG BOY HYDRANGEA	<i>Hydrangea</i> 'LDBOY'	36	2 1/2gal	POT
Jh	PRINCE OF WALES JUNIPER	<i>Juniperus horizontalis</i> 'Prince of Wales'	73	60cm	POT
Kf	KARL FOERSTER REED GRASS	<i>Calamagrostis acutifolia</i> 'Karl Foerster'	191	2 1/2gal	POT
L1	TULIP TREE	<i>Liriodendron tulipifera</i>	2	60cmcl	UB
Pf	WHITE SPRUCE	<i>Picea glauca</i>	6	150cm	UB
Pv	RUSSIAN SAGE	<i>Perovskia atriplicifolia</i>	11	2 1/2gal	POT
Qr	RED OAK	<i>Quercus rubra</i>	4	60cmcl	UB
Sb	SNOWGLOBE SPIREA	<i>Spiraea bunaldia</i> 'Snowglobe'	28	60cm	POT
Tc	DWARF JAPANESE YEW	<i>Taxus cuspidata</i> 'Nana'	28	60cm	POT
Ue	FINE LINE LEGELLA	<i>Weigela florida</i> 'Bravelli'	90	60cm	POT

LANDSCAPE PLAN

SCALE = 1:200

KEY	COMMON NAME	BOTANICAL NAME	QTY	SIZE	COND
Ar	MULTI-STEM SERVICEBERRY	<i>Amelanchier canadensis</i> multi-stem	2	150cm	POT
Cc1	SINGLE-STEM FOREST PANSY REDBUD	<i>Cercis canadensis</i> Forest Pansy	4	40cmcl	UB
Ge	ROZANE GERANIUM	<i>Geranium</i> 'Rozanne'	24	2 1/2gal	POT
Hb	ANNABELLE HYDRANGEA	<i>Hydrangea arborescens</i> 'Annabelle'	28	2 1/2gal	POT
Hb	BIG DADDY HOSTA	<i>Hosta</i> 'Big Daddy'	14	2 1/2gal	POT
Jh	BUFFALO JUNIPER	<i>Juniperus sibirica</i> 'Buffalo'	8	60cm	POT
Kf	KARL FOERSTER REED GRASS	<i>Calamagrostis acutifolia</i> 'Karl Foerster'	58	2 1/2gal	POT
Pv	WHITE SPRUCE	<i>Picea glauca</i>	3	150cm	UB
Pv	RUSSIAN SAGE	<i>Perovskia atriplicifolia</i>	44	2 1/2gal	POT
Ru	BLACK EYED SUSAN	<i>Rudbeckia fulgida</i> 'Goldstrum'	41	2 1/2gal	POT
Sa	AUTUMN JOY SEDUM	<i>Sedum spectabile</i> 'Autumn Joy'	26	2 1/2gal	POT
S1	CUTLEAF STEPHANANDRA	<i>Stephanandra</i> 'Iceberg Crisp'	26	30cm	POT
Tm	DENSE YEW	<i>Taxus media</i> 'Densiformis'	2	60cm	POT

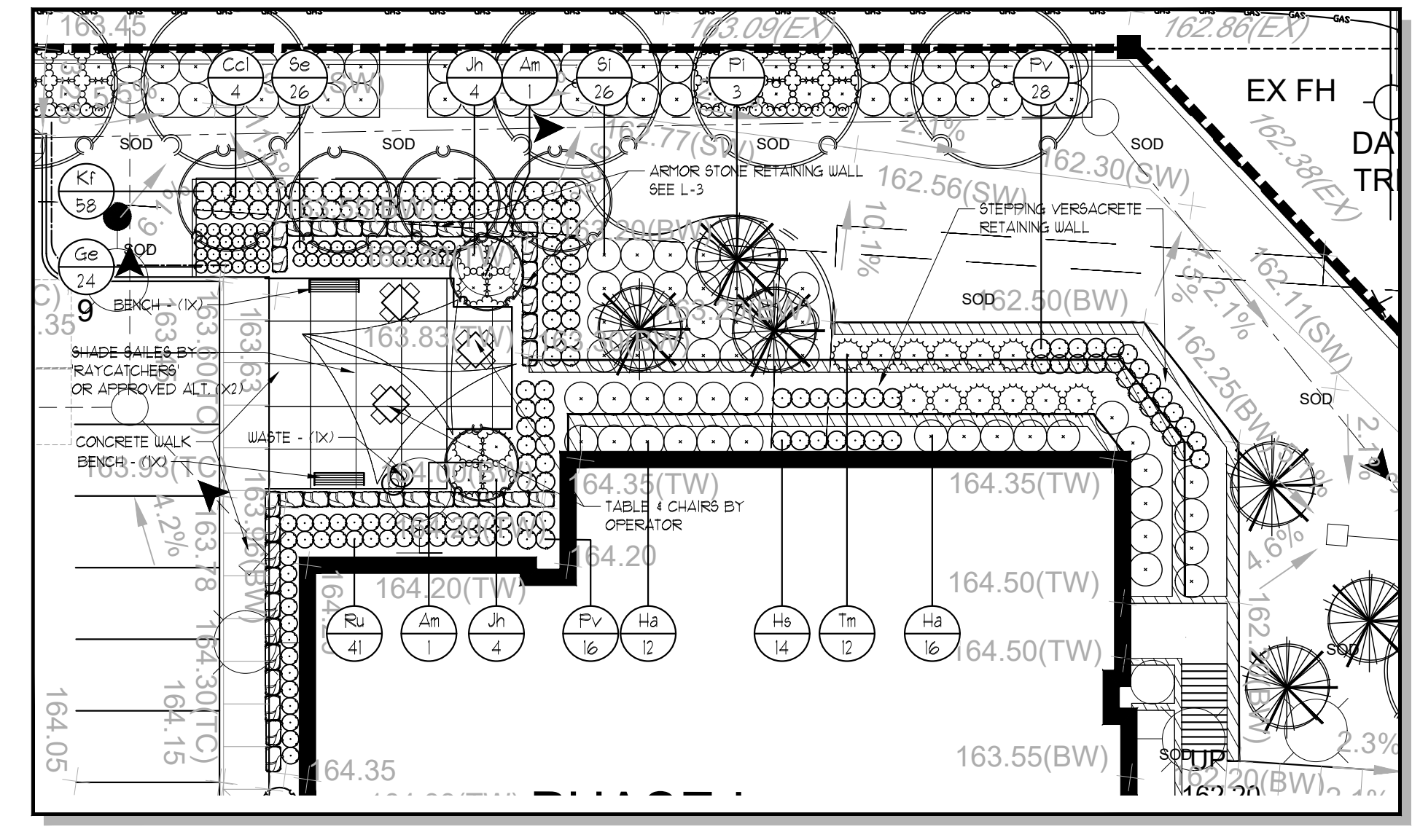

L-1

C:\Users\Mark\OneDrive\Documents\Projects\2024\22-237s\2024-07-11_12:41.pm

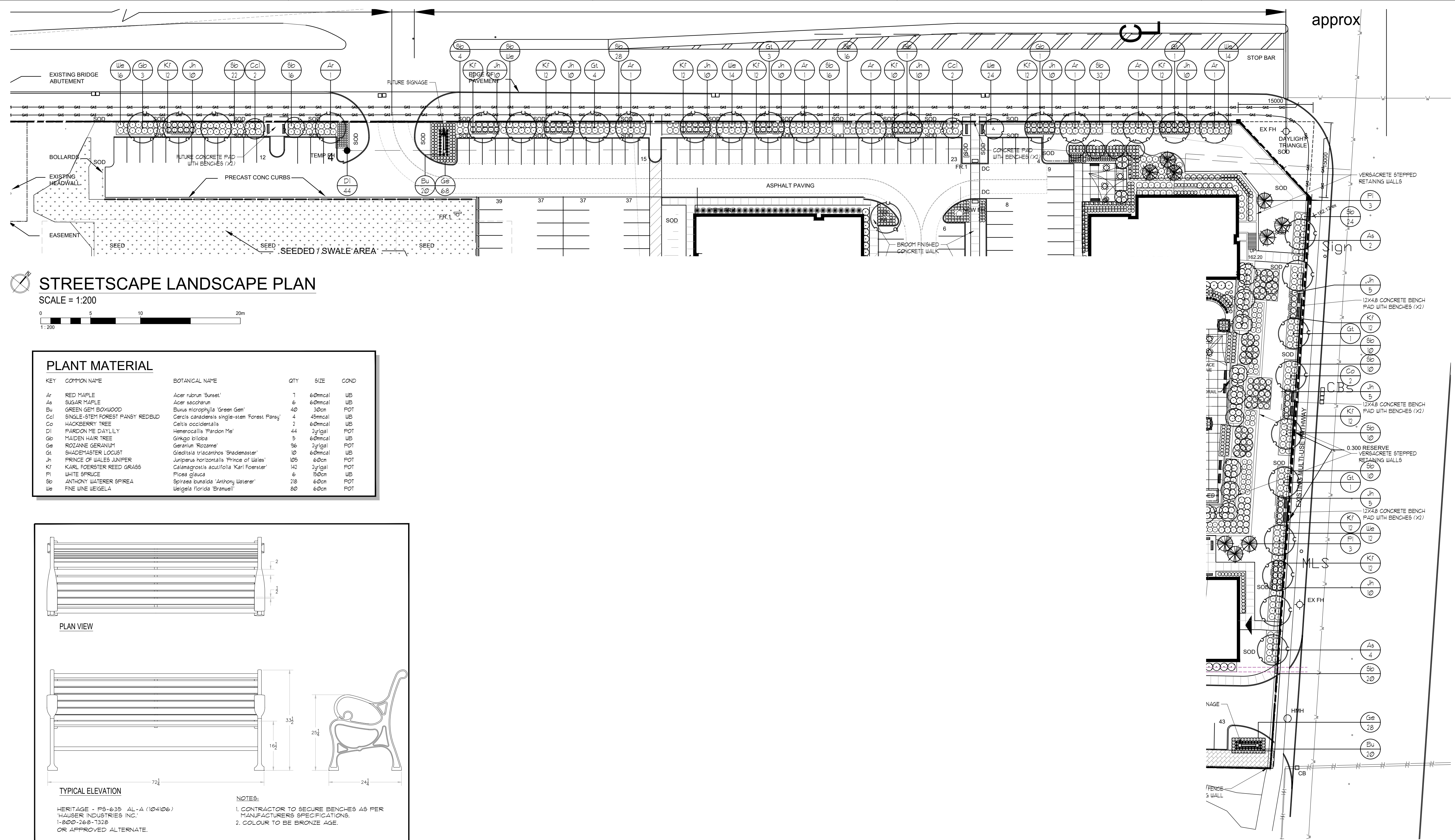
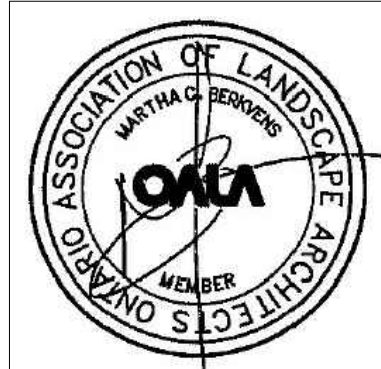

STREETSCAPE LANDSCAPE PLAN

SCALE = 1:200
 0 5 10 20m
 1:200

PLANT MATERIAL

KEY	COMMON NAME	BOTANICAL NAME	QTY	SIZE	COND
Ar	RED MAPLE	Acer rubrum 'Sunset'	1	60cmcl	UB
Aa	SUGAR MAPLE	Acer saccharum	6	60cmcl	UB
Bu	GREEN GEM BOXWOOD	Buxus microphylla 'Green Gem'	40	30cm	POT
Ccl	SINGLE-STEM FOREST PANSY REDBUD	Cercis canadensis 'single-stem Forest Pansy'	4	40cmcl	UB
Co	HACKBERRY TREE	Celtis occidentalis	2	60cmcl	UB
D1	PARDON ME DAYLILY	Hemerocallis 'Pardon Me'	44	2ygal	POT
Gp	MAIDEN HAIR TREE	Ginkgo biloba	5	60cmcl	UB
Ge	ROZANNE GERANIUM	Geranium Rozanne'	36	2ygal	POT
Gt	SHADEMASTER LOCUST	Gleditsia triacanthos 'Shademaster'	10	60cmcl	UB
Jh	PRINCE OF WALES JUNIPER	Juniperus horizontalis 'Prince of Wales'	105	60cm	POT
Kf	KARL FOERSTER REED GRASS	Calamagrostis acutifolia 'Karl Foerster'	142	2ygal	POT
Ph	WHITE SPRUCE	Picea glauca	6	150cm	UB
Sc	ANTHONY WATERER SPIREA	Spiraea bunaldii 'Anthony Waterer'	28	60cm	POT
We	FINE WINE WEIGELA	Weigela florida 'Brannell'	80	60cm	POT

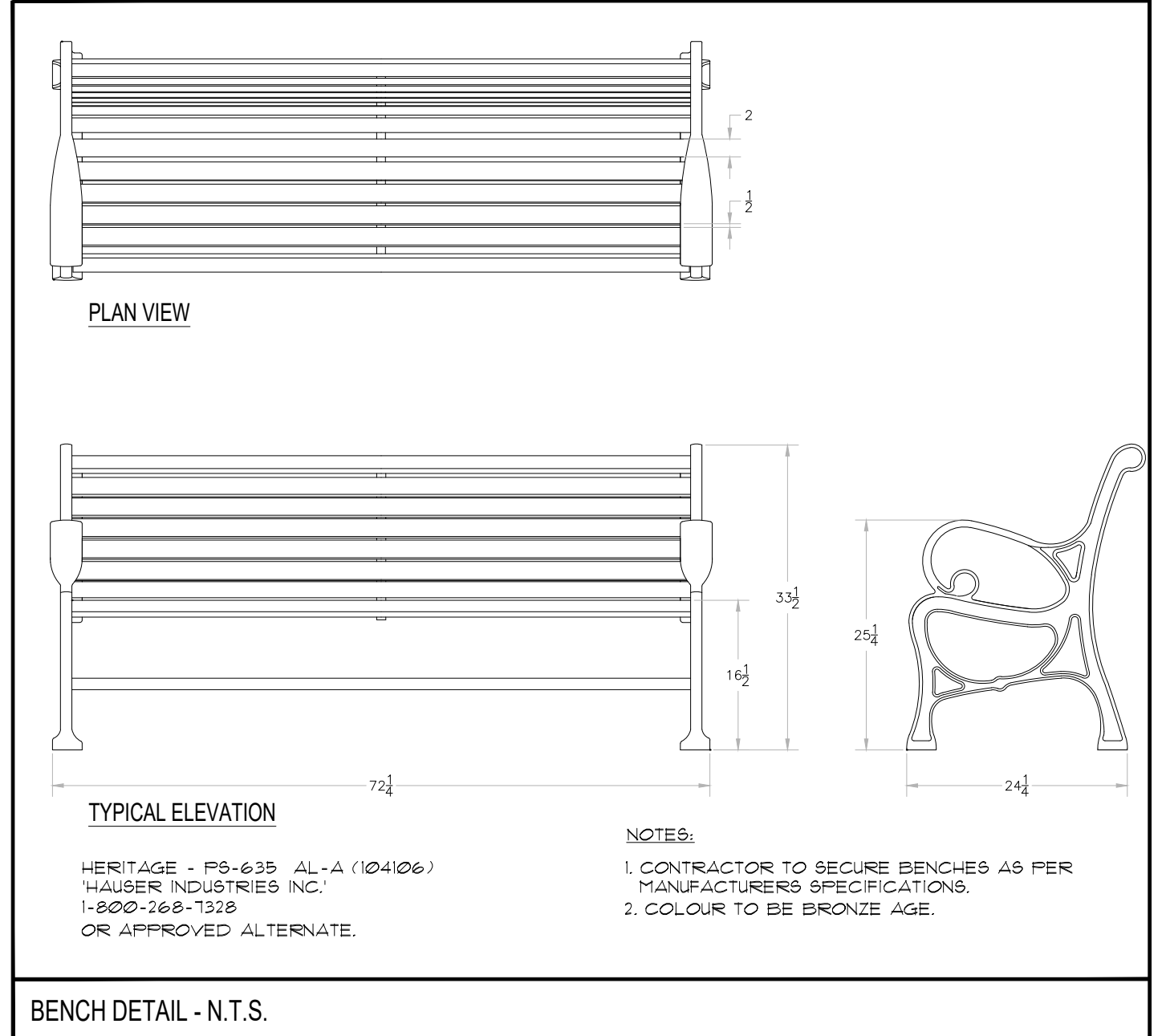

388 Queen Street East, London, Ontario, N6A 1V7

RON KOUROS
 ARCHITECTS
 LANDSCAPE ARCHITECTS

ISSUED FOR S.P.A.
 2024-07-11
 REISSUED FOR S.P.A.
 2024-07-11

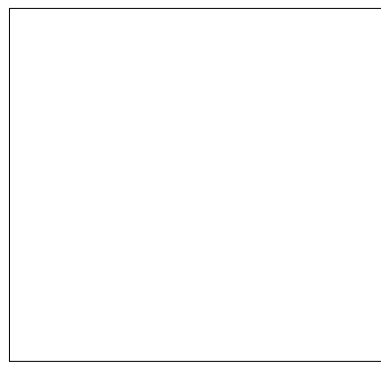

Schlegel Village - Oakville
 Schlegel Village
 2150 WILLIAM HALTON PARKWAY W. OAKVILLE ONTARIO

Project No.: 22-237s
 Drawn By: MCB
 Plot Date: 2024-07-12

STREETSCAPE LANDSCAPE PLAN

C:\Users\Aman\OneDrive\Temp\Aman\Aman_466022237s.dwg, 2024 Jul 11, 12:41 pm

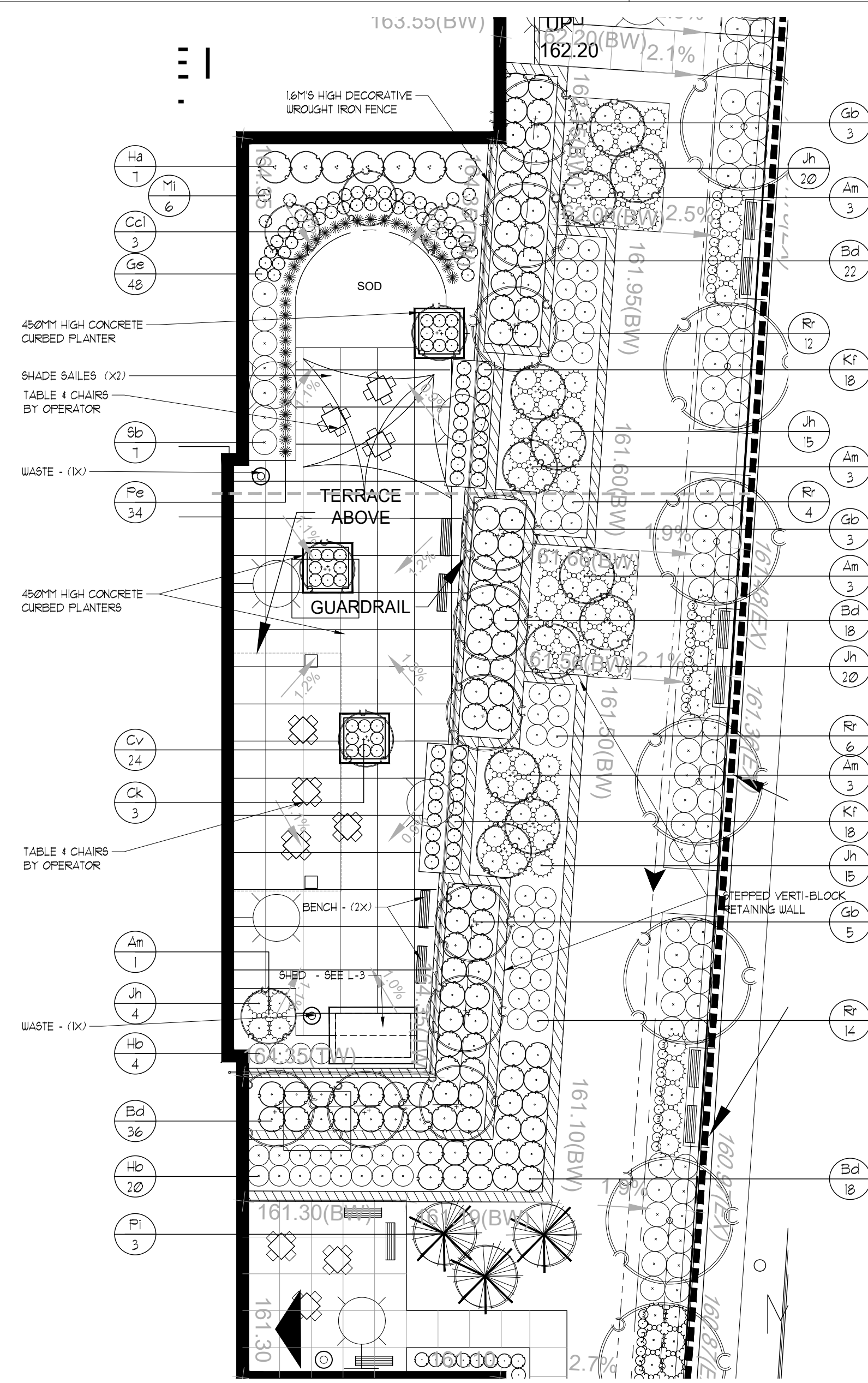

COURTYARD 'A' LANDSCAPE PLAN

SCALE = 1:200

KEY	COMMON NAME	BOTANICAL NAME	QTY	SIZE	COND
Am	MULTI-STEM SERVICEBERRY	<i>Amelanchier canadensis</i> multi-stem	13	250cm	UB
Bd	BUTTERFLY BUSH	<i>Buddleia</i>	94	2'rigal	POT
Ccl	SINGLE-STEM FOREST PANSY REDBUD	<i>Cercis canadensis</i> Forest Pansy	3	40mcal	UB
Ck	CHINESE FLOWERING DOGWOOD	<i>Cornus kousa</i> var. <i>chinensis</i>	3	150cm	POT
Cv	PURPLE CONE FLOWER	<i>Echinacea purpurea</i>	24	2'rigal	POT
Ge	MAIDEN HAIR TREE	<i>Ginkgo biloba</i>	1	60mcal	UB
Gs	ROZANNE GERANIUM	<i>Geranium 'Rozanne'</i>	48	2'rigal	POT
Hd	ANNABELLE HYDRANGEA	<i>Hydrangea arborescens</i> 'Annabelle'	1	2'rigal	POT
Hb	BOBO HYDRANGEA	<i>Hydrangea 'BOBO'</i>	14	2'rigal	POT
Jh	BUFFALO JUNIPER	<i>Juniperus sibirica</i> 'Buffalo'	14	60cm	POT
Kf	KARL FOERSTER REED GRASS	<i>Calamagrostis acutifolia</i> 'Karl Foerster'	36	2'rigal	POT
Mi	HURON SUNRISE MAIDEN GRASS	<i>Miscanthus sinensis</i> 'Huron Sunrise'	6	2'rigal	POT
Pe	LITTLE BUNNY FOUNTAIN GRASS	<i>Festuca sibirica</i> 'Little Bunny'	24	2'rigal	POT
Pi	WHITE SPRUCE	<i>Picea glauca</i>	3	200cm	UB
Rr	THE FAIRY SHRUB ROSE	<i>Rosa rugosa</i> 'The Fairy'	36	60cm	POT
Sb	ANTHONY WATERER SPIREA	<i>Spiraea vanillae</i> 'Anthony Waterer'	1	60cm	POT

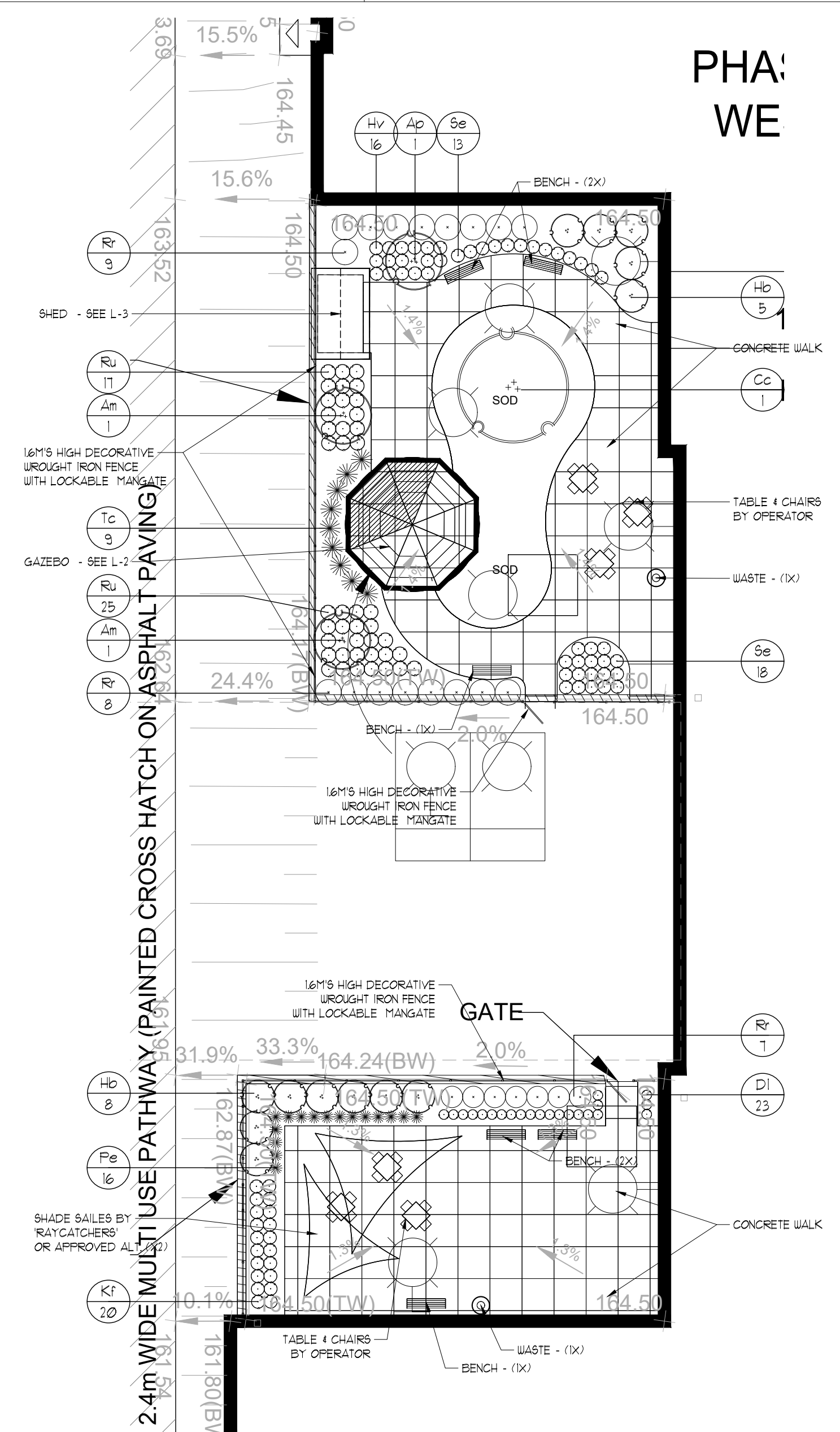

COURTYARDS 'B' & 'C' LANDSCAPE PLAN

SCALE = 1:200

KEY	COMMON NAME	BOTANICAL NAME	QTY	SIZE	COND
Am	MULTI-STEM SERVICEBERRY	<i>Amelanchier canadensis</i> multi-stem	2	200cm	UB
Ap	BLOODGOOD JAPANESE MAPLE	<i>Acer palmatum</i> 'Bloodgood'	1	50cm	UB
Cc	SINGLE-STEM FOREST PANSY REDBUD	<i>Cercis canadensis</i> Forest Pansy	1	40mcal	UB
Di	PARDON THE DAYLILY	<i>Hemerocallis 'Pardon Me'</i>	23	2'rigal	POT
Hb	BOBO HYDRANGEA	<i>Hydrangea 'BOBO'</i>	13	2'rigal	POT
Hv	VARIEGATED HOSTA	<i>Hosta undulata</i> 'Variegata'	16	2'rigal	POT
Kf	KARL FOERSTER REED GRASS	<i>Calamagrostis acutifolia</i> 'Karl Foerster'	20	2'rigal	POT
Ru	LITTLE BUNNY FOUNTAIN GRASS	<i>Festuca sibirica</i> 'Little Bunny'	16	2'rigal	POT
Rr	THE FAIRY SHRUB ROSE	<i>Rosa rugosa</i> 'The Fairy'	24	60cm	POT
Rt	BLACK EYED SUSAN	<i>Rudbeckia fulgida</i> 'Goldsturm'	42	2'rigal	POT
Se	AUTUMN JOY SEDUM	<i>Sedum spectabile</i> 'Autumn Joy'	3	2'rigal	POT
Tc	DIWAR JAPANESE YEW	<i>Taxus cuspidata</i> 'Nana'	1	3gal.	POT

PHA:
WE

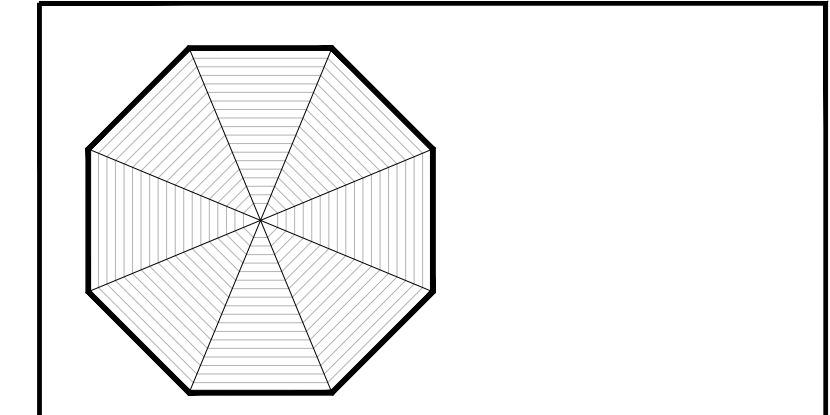

- GAZEBO - N.T.S.**
- CONTRACTOR TO SUPPLY AND INSTALL A 62" x 20" x 20" DIA GAZEBO BY LIMESTONE TRAILS OR APPROVED ALTERNATE.
 - COLOR, ROOF MATERIAL AND CUPOLA TO BE CONFIRMED BY OWNER.
 - UNIT MOUNTED ON CONCRETE SLABS FLUSH WITH CONCRETE TERRACE. NO FLOOR OR STEPS UP SPECIFIED.
 - APPLY RAILINGS AS INDICATED.
 - PROVIDE ELECTRICAL OUTLET 1 HANGING PENDANT LIGHT AND 8 POST MOUNTED LIGHTS - CONFIRM WITH ELECTRICAL.
 - PROVIDE STAMPED DETAILS FOR APPROVAL.



- SHEDS - N.T.S.**
- CONTRACTOR TO SUPPLY AND INSTALL 2 - 8'x11' LIMESTONE TRAILS OR APPROVED ALTERNATE.
 - COLOR TO BE CONFIRMED BY OWNER.
 - UNIT MOUNTED ON CONCRETE SLABS FLUSH WITH CONCRETE TERRACE. NO FLOOR OR STEPS UP SPECIFIED.
 - PROVIDE GFI ELECTRICAL OUTLETS AND INTERIOR LIGHTS - CONFIRM WITH ELECTRICAL.

GENERAL PLANTING SPECIFICATIONS:

- BASE INFORMATION SUPPLIED BY CORNERSTONE ARCHITECTURE.
- CONTRACTOR TO MAKE THEMSELVES FAMILIAR WITH ALL RELATED SPECIFICATIONS.
- CONTRACTORS ARE RESPONSIBLE FOR REVIEW OF ALL SPECIFICATIONS AND RELATED DRAWINGS WITH SELECTED SUB-CONTRACTORS AS THEY PERTAIN TO WORK AS OUTLINED ON LANDSCAPE ARCHITECTURAL WORKING DRAWINGS AND SPECIFICATIONS.
- REPORT ALL DISCREPANCIES TO THE LANDSCAPE ARCHITECT DURING TENDERING PROCESS. ERRORS AND/OR OMISSIONS WILL BE THE RESPONSIBILITY OF THE CONTRACTOR.
- CONTRACTOR SHALL MAINTAIN ALL LANDSCAPED AREAS UNTIL OWNER ACCEPTANCE OF PROJECT. CONTRACTOR TO NOTIFY LANDSCAPE ARCHITECT IN WRITING ON COMPLETION OF PROJECT FOR A SITE WORK COMPLETION CERTIFICATE AS WELL AS THE COMPLETION OF THE ACCEPTANCE OF PROJECT.
- ALL WORKMANSHIP TO BE WARRANTED FOR ONE YEAR UNLESS OTHERWISE STATED. WARRANTY PERIOD WILL BEGIN ON FINAL ACCEPTANCE OF PROJECT.
- ALL WORKMANSHIP TO BE TO THE STANDARDS OF THE ONTARIO LANDSCAPE ASSOCIATION AND THE LANDSCAPE ONTARIO SPECIFICATION STANDARDS.
- ALL NURSERY STOCK TO BE "NURSERY GROWN AND MUST COMPLY WITH "GUIDE SPECIFICATION FOR NURSERY STOCK OF THE CANADIAN NURSERY TRADES ASSOCIATION".
- ALL LANDSCAPING IS TO BE INSTALLED PRIOR TO THE END OF THE FIRST GROWING SEASON FOLLOWING THE OCCUPANCY OF THE SITE DEVELOPMENT UNLESS OTHERWISE STATED.
- CONTRACTOR IS RESPONSIBLE FOR ALL UNDERGROUND UTILITIES AND MUST SUPPLY THE LANDSCAPE ARCHITECT WITH COPIES OF LOCATE CERTIFICATES PRIOR TO COMMENCEMENT OF WORK.

- GRADING -**
- CONTRACTOR TO ENSURE POSITIVE DRAINAGE IN ALL AREAS.
 - ALL GRADING TO BE IN ACCORDANCE WITH SITE ENGINEERS DRAWINGS.
 - SOIL SHALL BE SCARIFIED FREE OF ALL STONES, ROOTS, BRANCHES LARGER THAN 1" (25MM) AND COMPACTED TO 95% SPD.
 - ALL SUBSOIL TO BE SCARIFIED TO A DEPTH OF 6" (150MM) PRIOR TO THE INSTALLATION OF TOPSOIL TO ENSURE NO HARDPAN CONDITIONS.
 - CONTRACTOR TO NOTIFY LANDSCAPE ARCHITECT PRIOR TO INSTALLATION OF TOPSOIL TO APPROVE SUBBASE.
 - DIRECT ALL RAIN LEADERS AND SUMP LEADERS AWAY FROM PLANTING BEDS AND TO THE DESIGNATED SUALES.
 - NOTIFY LANDSCAPE ARCHITECT IN WRITING OF ANY SUBSTANTIAL USE CONDITIONS.

- TOPSOIL -**
- AT THE CONTRACTORS EXPENSE A SOIL TEST IS TO BE COMPLETED BY A REPUTABLE LABORATORY. THE SOIL TEST IS TO BE COMPLETED AND IF NECESSARY RECOMMENDATIONS FROM THE LABORATORY ARE TO BE INCLUDED. THE RESULTS OF SOIL TESTS AND RECOMMENDATIONS ARE TO BE PROVIDED TO THE LANDSCAPE ARCHITECT FOR APPROVAL ONE WEEK PRIOR TO WORK COMMENCEMENT.
 - TOPSOIL FOR PLANTING BEDS IS TO BE A TRIPLE MIX (1/3 TOPSOIL, 1/3 PEATMOSS, 1/3 COMPOST) - FERTILE, FRIABLE, NATURAL LOAM TO A MINIMUM DEPTH OF 8" (450MM) AND A MINIMUM DEPTH OF 4" (100MM) FOR TREE AREAS - UNLESS OTHERWISE STATED - TOPSOIL SHALL CONTAIN NOT LESS THAN 5% ORGANIC MATTER FOR CLAY LOAMS AND NOT LESS THAN 2% ORGANIC MATTER FOR SANDY LOAM TO A MAXIMUM OF 8% AND CAPABLE OF SUSTAINING VIGOROUS PLANT GROWTH FREE OF SUBSOIL CONTAMINATION, ROOTS AND STONES OVER 50MM DIAMETER, REASONABLY FREE OF WEEDS, AS DETERMINED BY THE LANDSCAPE ARCHITECT, AND HAVING A PH RANGING FROM 6.0 TO 7.0.

- MULCH -**
- ALL TREEPITS SHRUB PITS AND PLANTING AREAS ARE TO BE MULCHED UNLESS OTHERWISE NOTED.
 - CONTRACTOR TO INSTALL 3" (75MM) OF HEMLOCK SHREDDED MULCH IN ALL AREAS.
 - ALTERNATIVES MAY BE ACCEPTED - CONTRACTOR TO PROVIDE 3 SAMPLES FOR WRITTEN APPROVAL TO THE LANDSCAPE ARCHITECT.

- PLANT MATERIALS -**
- CONTRACTOR TO VERIFY ALL PLANT MATERIAL ON DRAWING(S) AND PLANT MATERIAL LIST(S). REPORT ALL DISCREPANCIES AT TENDERING PROCESS.
 - SUBSTITUTIONS WILL NOT BE ACCEPTED WITHOUT WRITTEN CONFIRMATION BY THE LANDSCAPE ARCHITECT AND THE CITY OF WATERLOO.
 - PLANTINGS MAY BE ADJUSTED TO SUIT UTILITIES STRUCTURES AND AESTHETIC CONCERNS. ADJUSTMENTS ARE TO BE MADE UNDER DIRECTION OF THE LANDSCAPE ARCHITECT. ADJUSTMENTS WITHOUT CONSENT OF LANDSCAPE ARCHITECT AND/OR PROJECT MANAGER MAY NOT MEET INTENT OF DESIGN AND/OR MUNICIPAL APPROVALS. PLANT MATERIAL THAT HAS TO BE RELOCATED AS A RESULT WILL BE AT THE COST OF THE CONTRACTOR.
 - LANDSCAPE ARCHITECT TO INSPECT ALL PLANT MATERIAL ON SITE OR AT ITS SOURCE PRIOR TO INSTALLATION. CONTRACTOR IS TO GIVE LANDSCAPE ARCHITECT 48 HRS NOTICE FOR INSPECTION.
 - CONTRACTOR TO NOTIFY LANDSCAPE ARCHITECT IN WRITING IF ADVERSE WEATHER MAY IMPACT THE HEALTH OF THE PLANT MATERIALS AT THE TIME OF PLANTING. IE TEMPERATURE, PRECIPITATION.
 - ALL TREE PITS SHALL BE AT LEAST 2 FT. (600MM) WIDER THAN BALL OF THE TREE TO BE PLANTED AND SHALL BE DEEP ENOUGH SO THAT THE TOP OF BALL IS AT THE SAME LEVEL AS SURROUNDING GRADE. A MINIMUM OF 6" (150MM) OF BACKFILL SHALL BE PLACED UNDER BALL. TREE PITS ARE NOT TO BE LEFT OPEN OVER NIGHT.
 - SHRUB BEDS SHALL BE EXCAVATED TO A DEPTH OF 18" (450MM) AND FILLED WITH APPROVED BACKFILL MATERIAL. SHRUB BEDS ARE NOT TO BE LEFT OPEN OVER NIGHT.
 - ALL TREES SHALL HAVE AN EARTH SAUCER AT ITS BASE WITH A DIAMETER AS LARGE AS EXCAVATED AREA AND SHAPED TO RETAIN WATER (SEE DETAIL). EARTH SAUCER TO HAVE APPROVED MULCH INSTALLED TO A MINIMUM DEPTH OF 15" (63MM).
 - ALL BURLAP SHALL BE CUT AND BURIED BELOW SURFACE DURING PLANTING.
 - ALL EVERGREENS ARE TO UNBARRIED THE FIRST WINTER AT THE EXPENSE OF THE LANDSCAPE CONTRACTOR.
 - DIRECT ALL RAIN LEADERS AND SUMP LEADERS AWAY FROM PLANTING BEDS AND TO DESIGNATED DRAINAGE SUALES.
 - DO NOT INSTALL PLANT MATERIAL IN DRAINAGE SUALES.
 - CONTRACTOR IS TO REMOVE ALL GUY WIRES AFTER 2 FULL GROWING SEASONS.



TRANSLUCENTS
Rich hues that reward the eye.

SATURATED
Color that stands out in a crowd.

PER EMAIL FROM OWNER 2016-08-16

REFER TO SANSIN STAIN COLOUR CHART ON FOLLOWING PAGE FOR STAIN COLOURS TO MATCH THIS PHOTO

BUTTERNUT 22 TO MATCH THIS PHOTO

WHAT SANSIN PRODUCT SHOULD I CHOOSE?
You've picked a color - now what product should you use to get the tone and look you want?

GAZEBO - N.T.S.



380 Oakes Street East, London, Ontario, N6A 1Y7

ISSUED FOR S.P.A. 2024-01-11

REISSUED FOR S.P.A. 2024-07-11

RON KOUDRY ARCHITECTS

Schlegel Village - Oakville

2150 WILLIAM HALTON PARKWAY W. OAKVILLE ONTARIO

Project No.: 22-275

Drawn By: MCB

Plot Date: 2024-07-12

LANDSCAPE PLAN & DETAILS

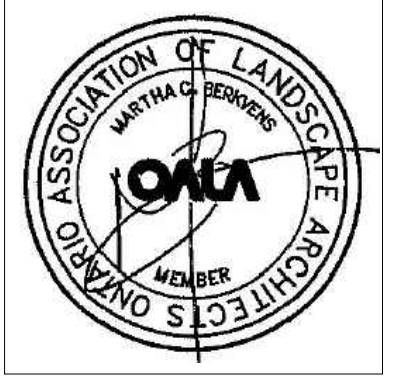

ISSUED FOR SFP
 2024-07-11
 2024-07-11
 REISSUED FOR SFA

345 DUNDAS ST. W. TORONTO, ONT. M5G 1C5
 416-593-9333
 RON KOUJARS
 ARCHITECTS

Schlegel Village
 2150 WILLIAM HALTON PARKWAY W. OAKVILLE, ONTARIO

Project No.: 22-237s
 Drawn By: MCB
 Plot Date: 2024-07-12

LANDSCAPE DETAILS

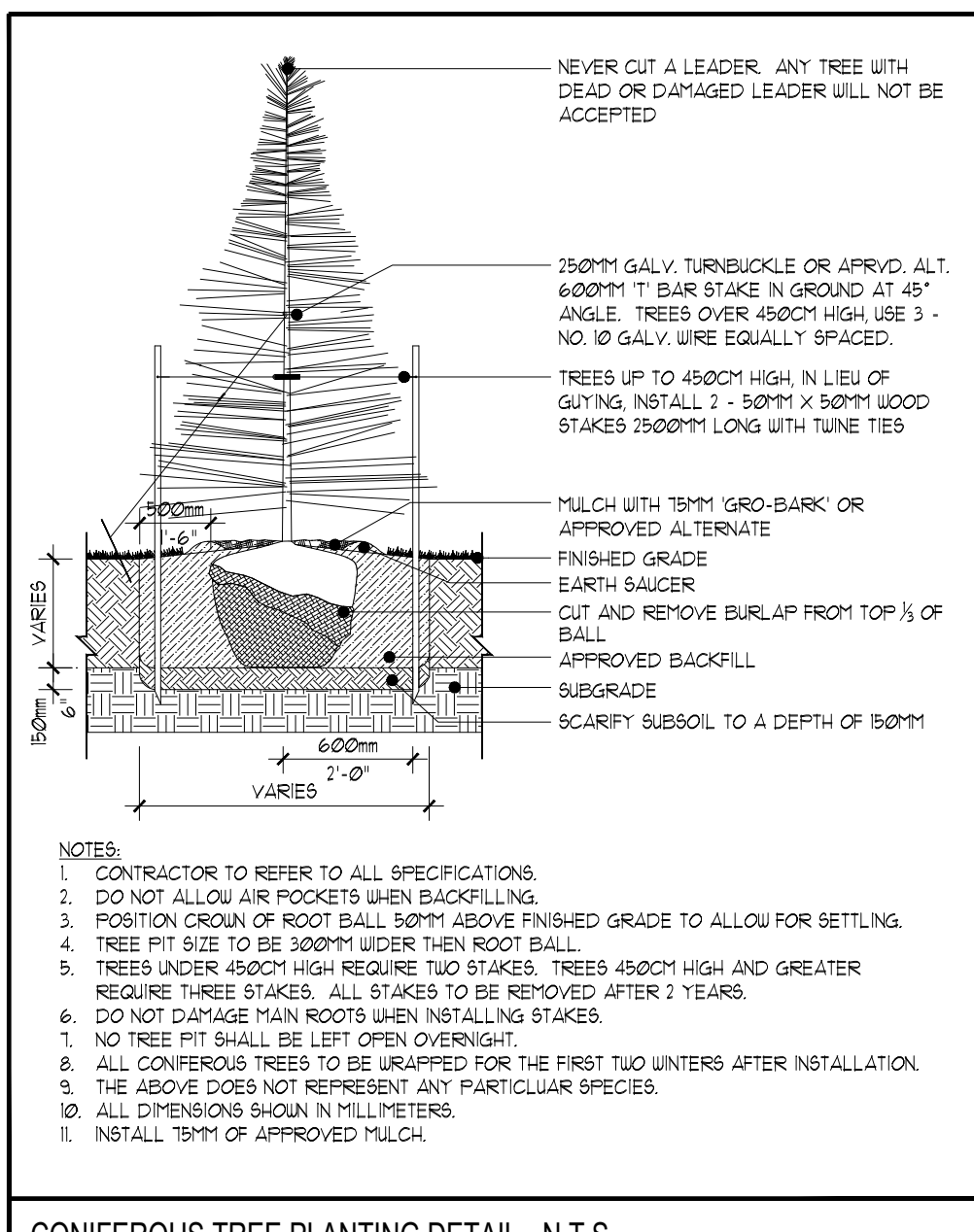

CONIFEROUS TREE PLANTING DETAIL - N.T.S.

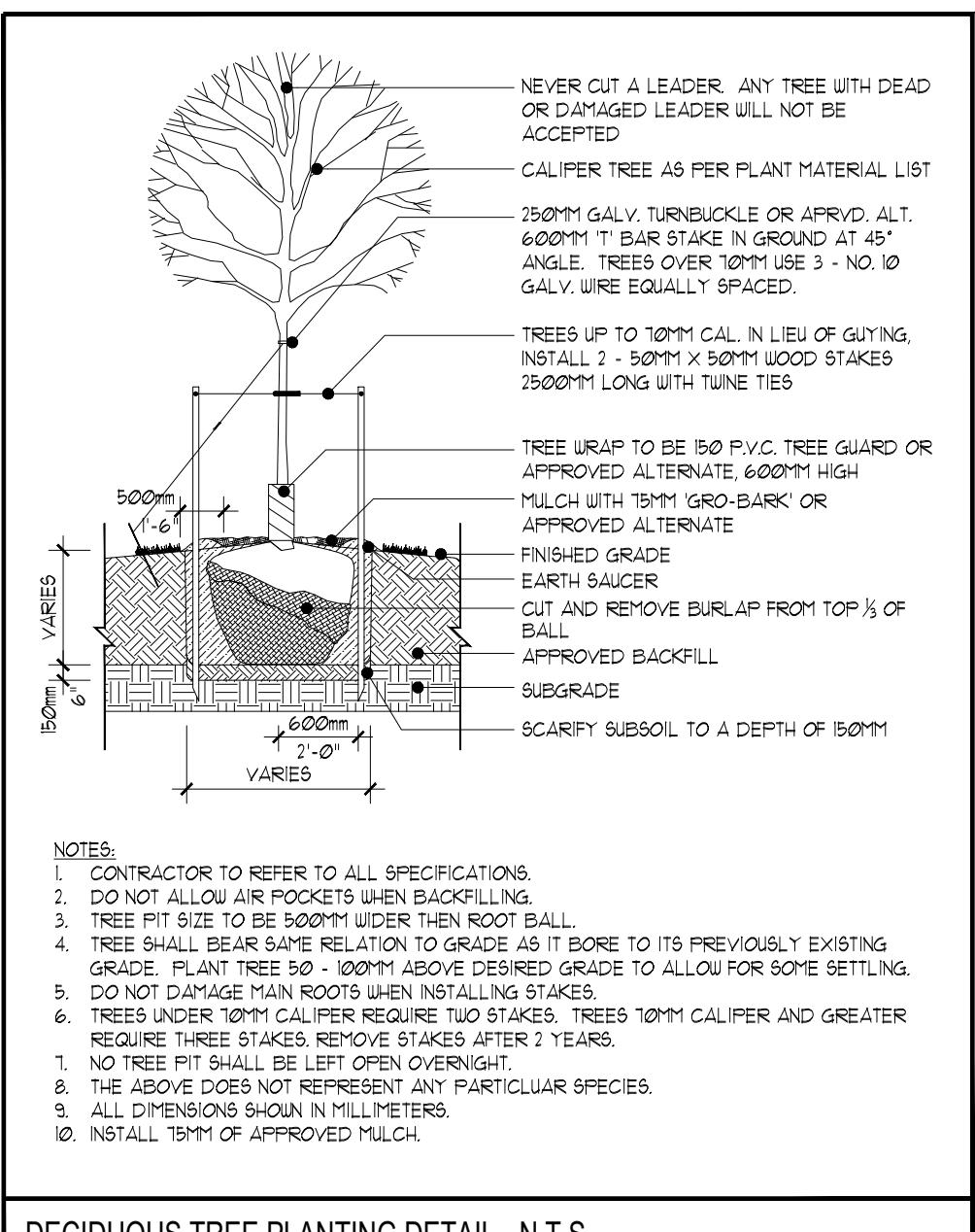

DECIDUOUS TREE PLANTING DETAIL - N.T.S.

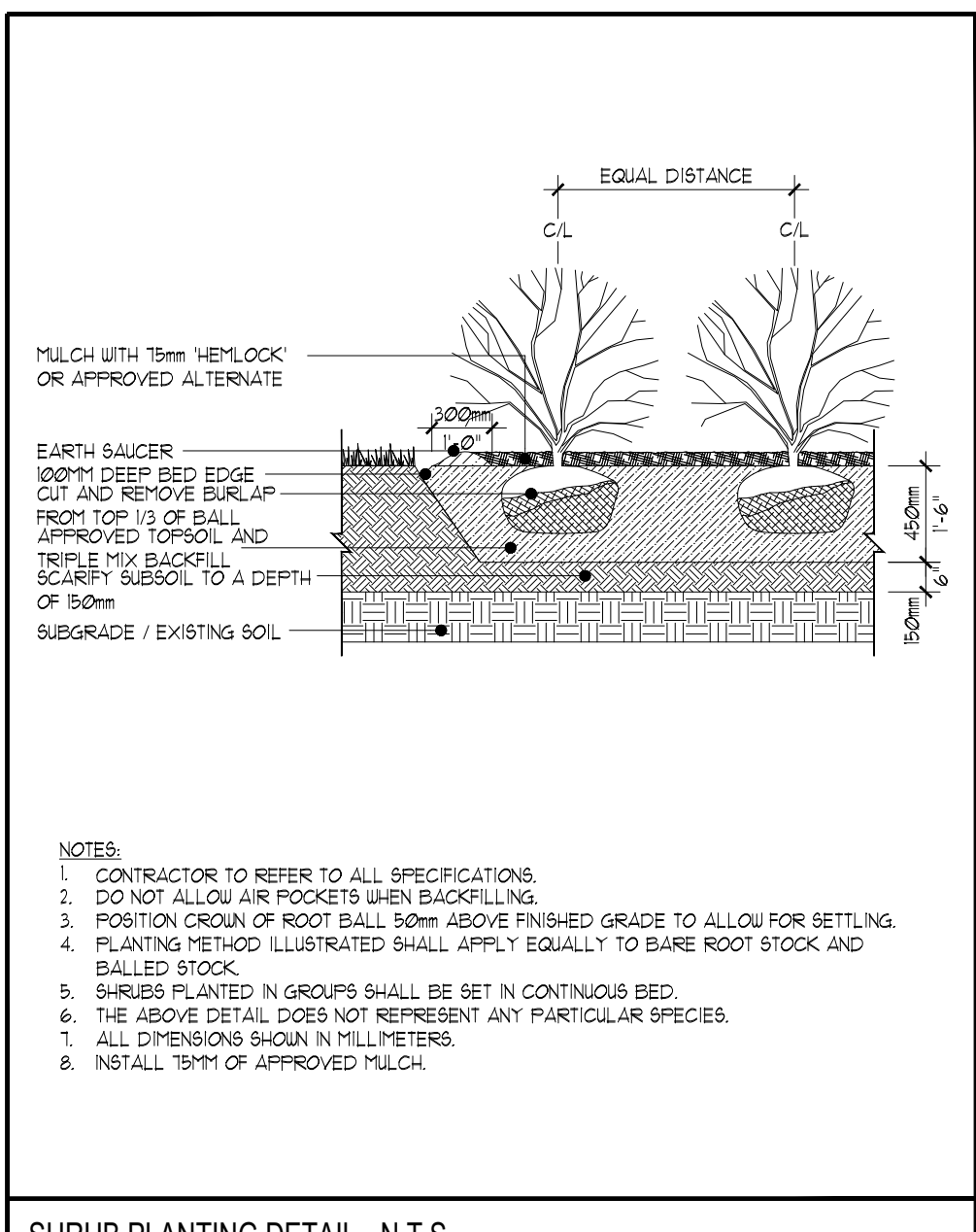

SHRUB PLANTING DETAIL - N.T.S.

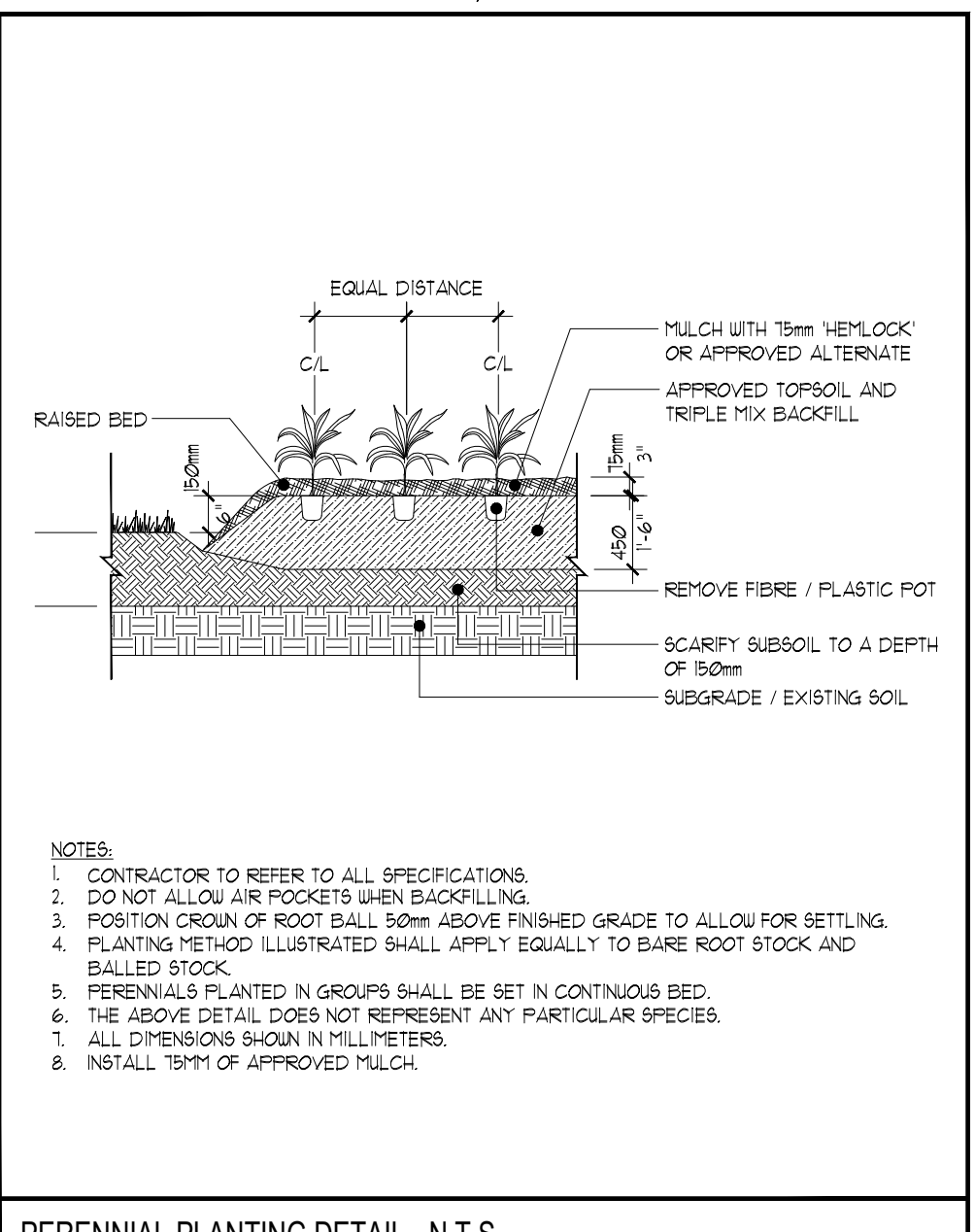

PERENNIAL PLANTING DETAIL - N.T.S.

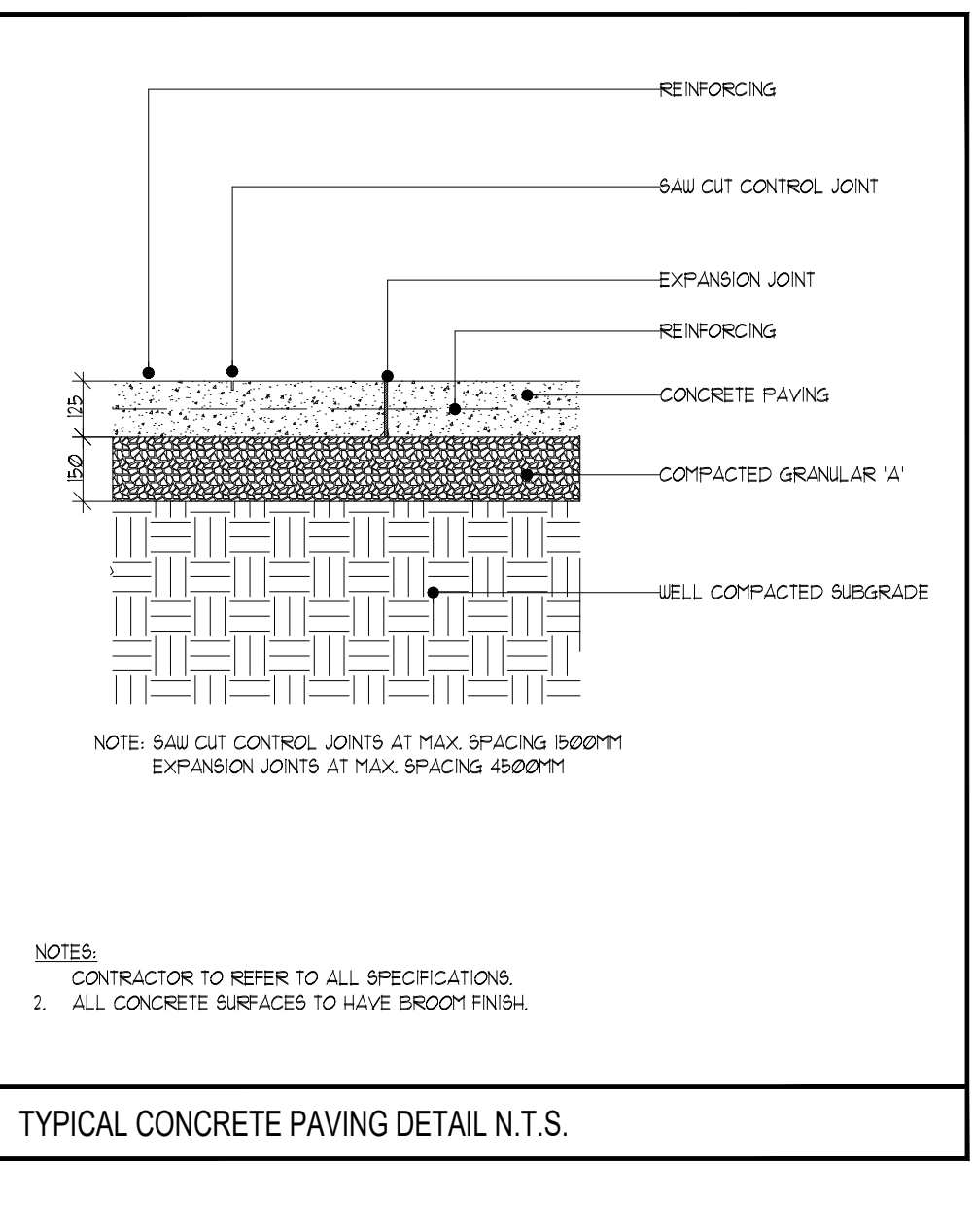

TYPICAL CONCRETE PAVING DETAIL N.T.S.

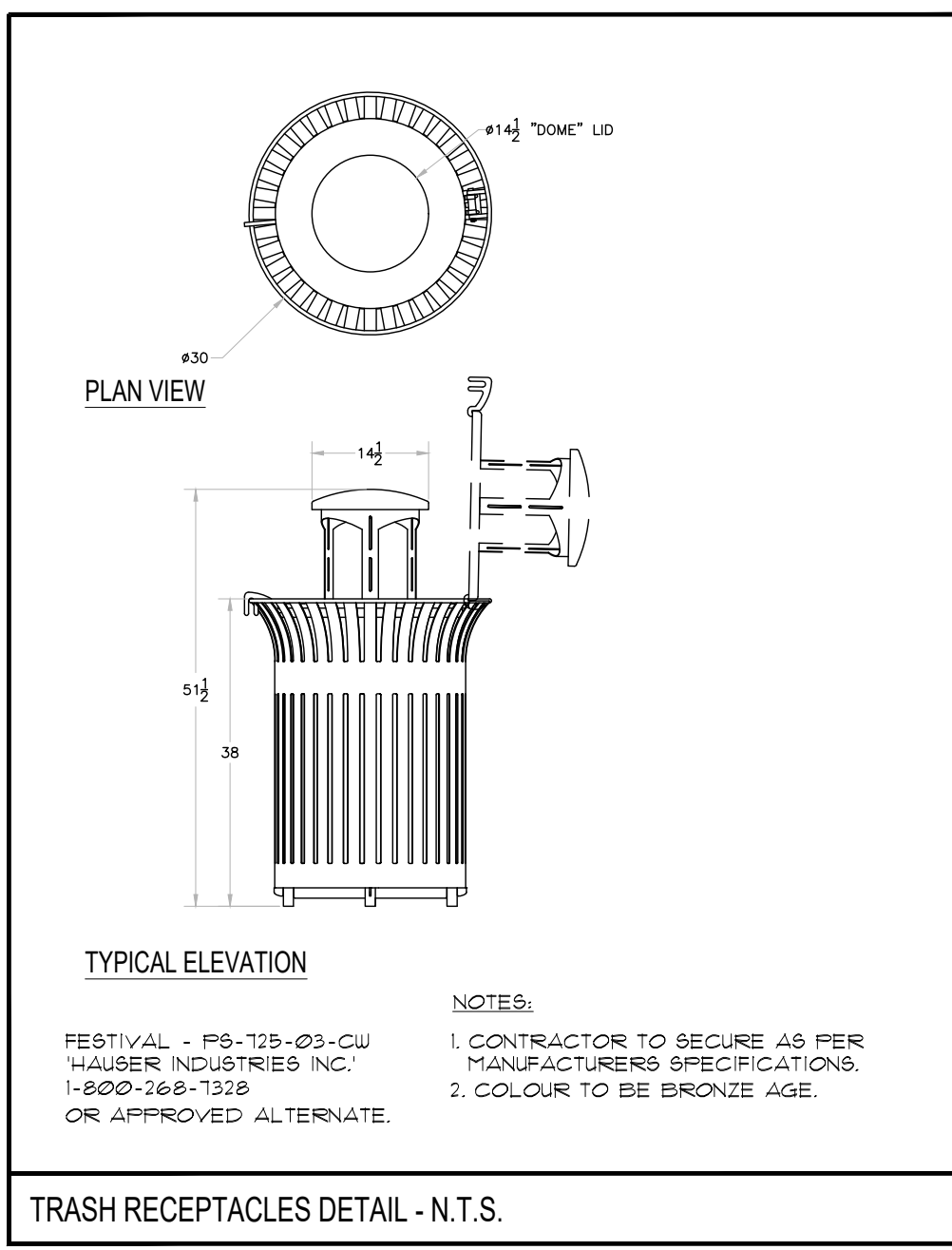

TRASH RECEPTACLES DETAIL - N.T.S.

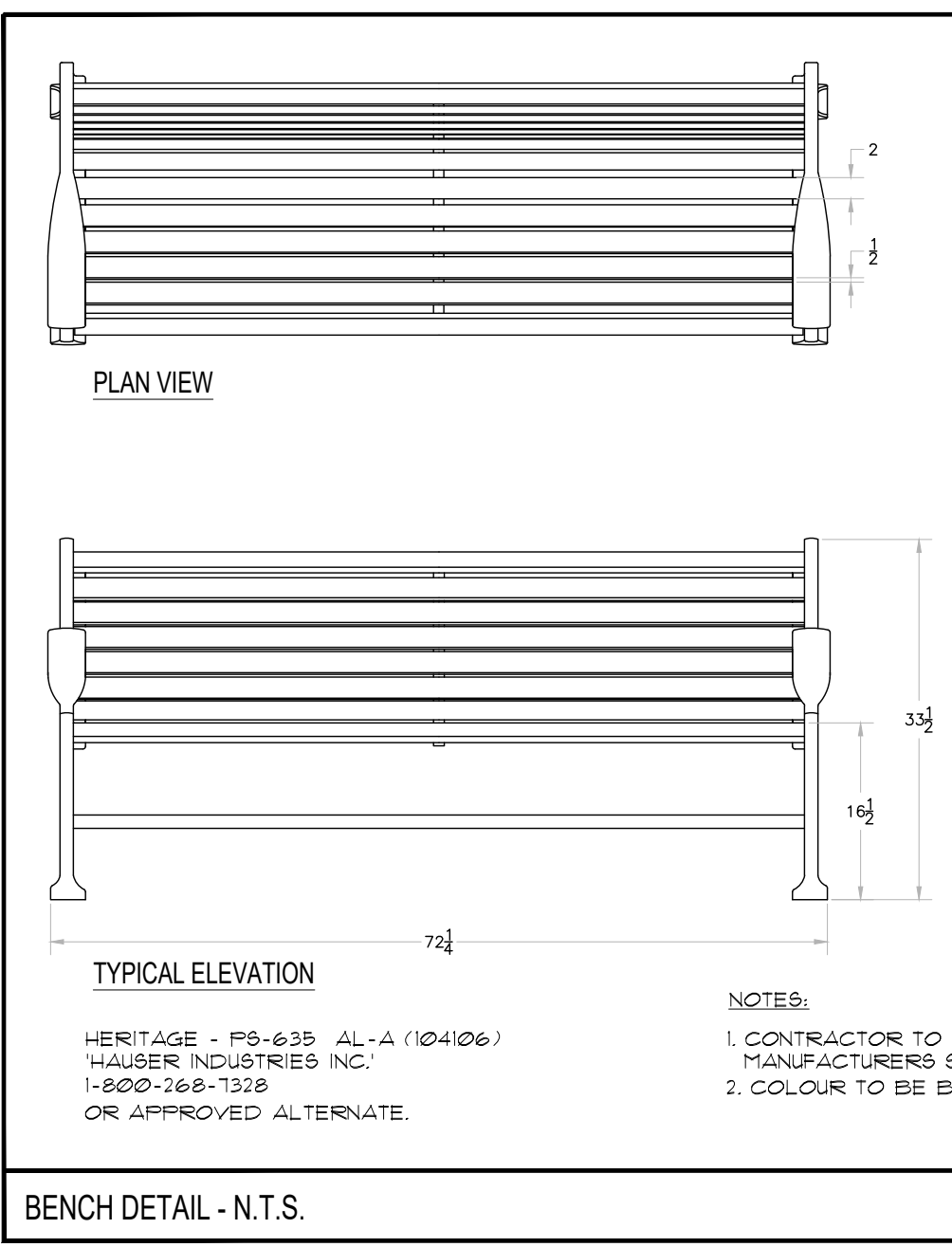

BENCH DETAIL - N.T.S.

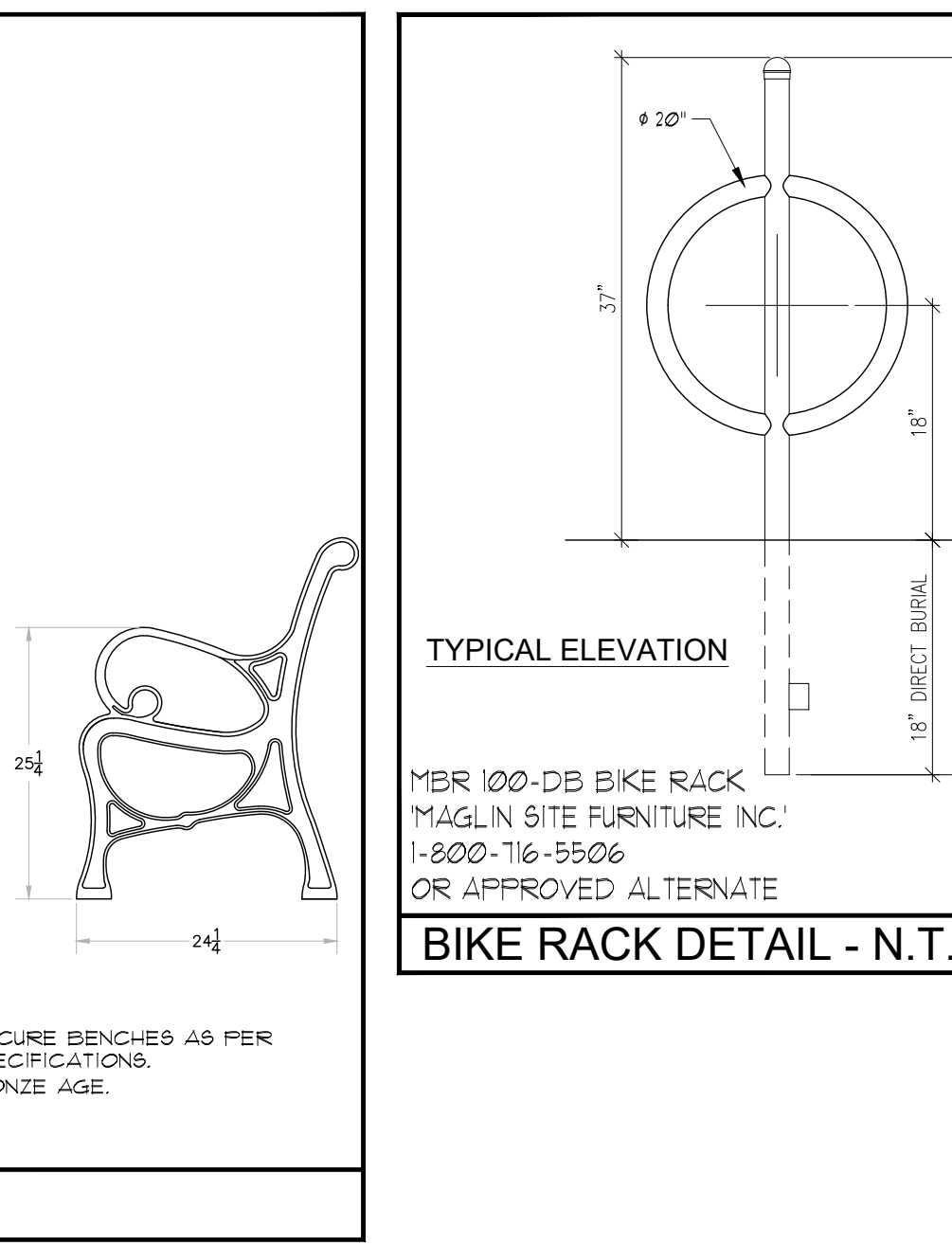

BIKE RACK DETAIL - N.T.S.

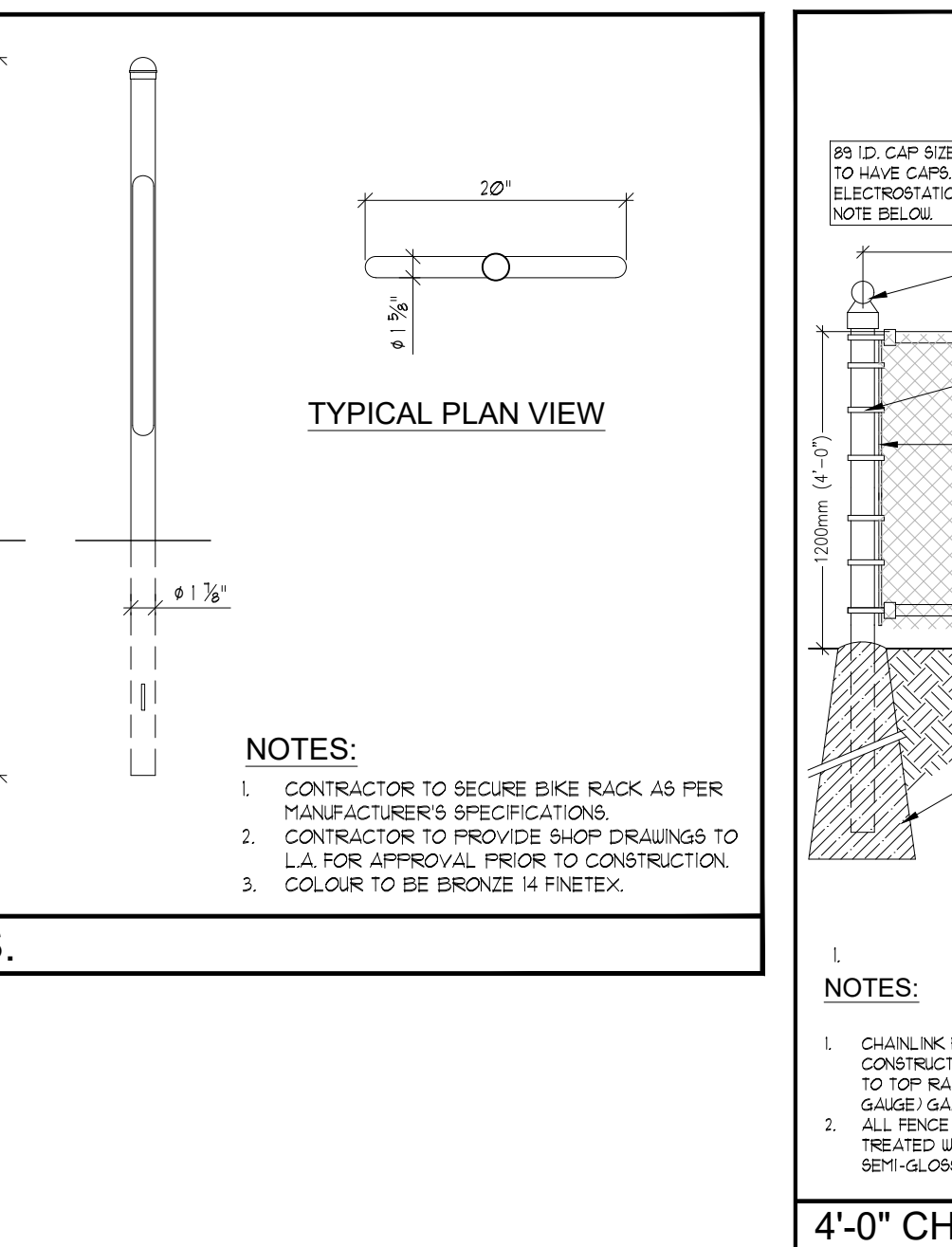

4'-0" CHAIN LINK FENCE DETAIL - N.T.S.

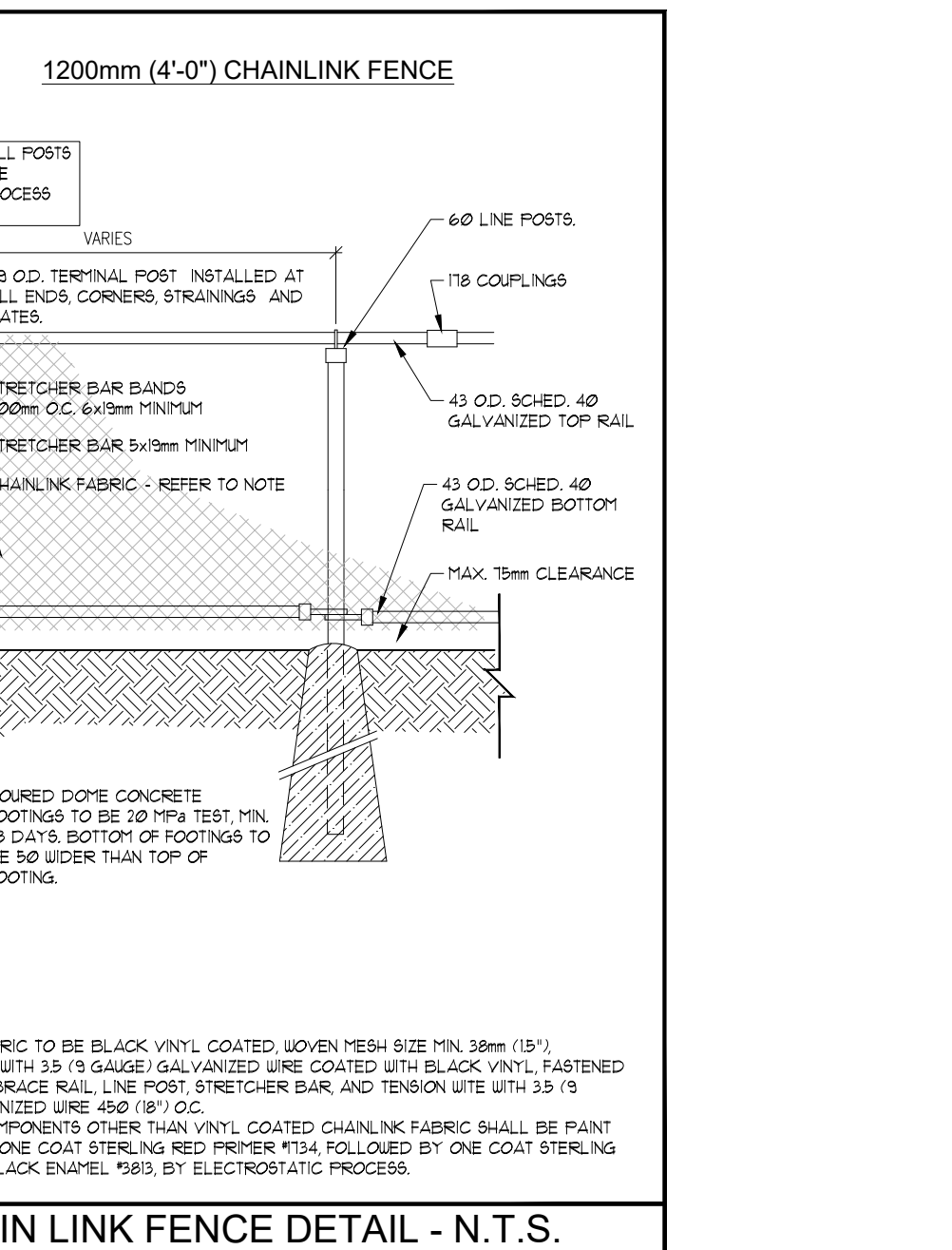

1200mm (4'-0") CHAINLINK FENCE DETAIL - N.T.S.

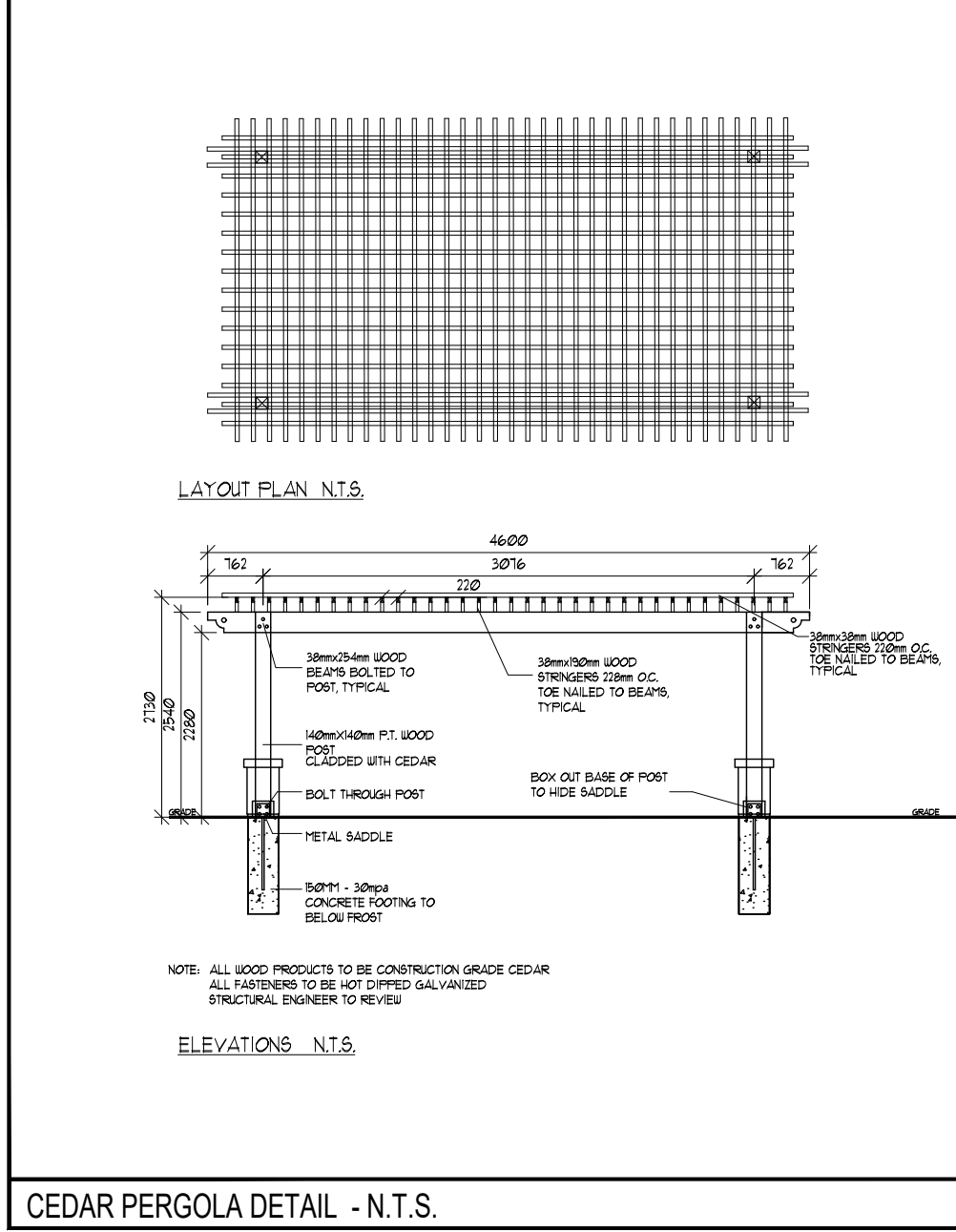

CEDAR PERGOLA DETAIL - N.T.S.

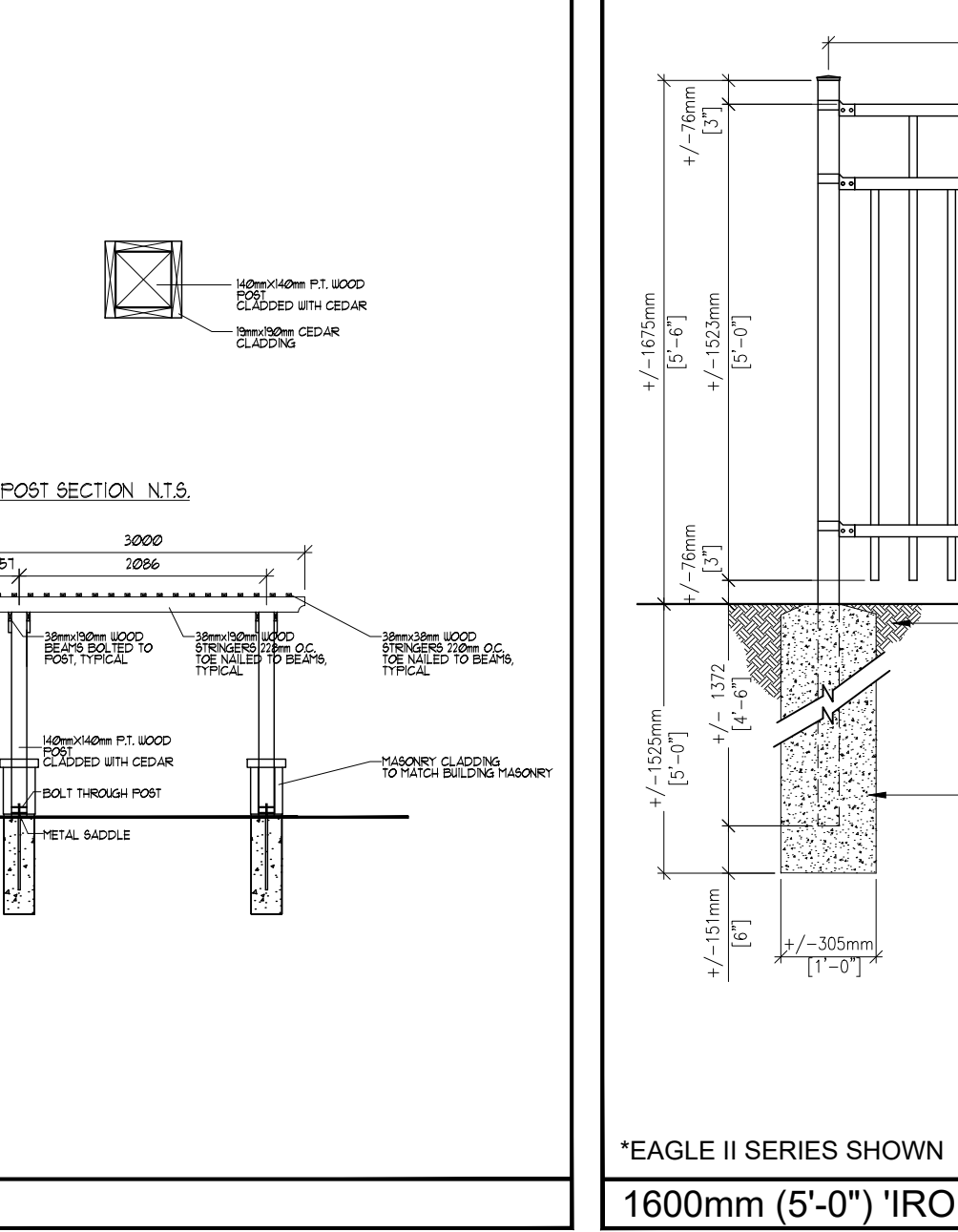

1600mm (5'-0") 'IRON EAGLE' WROUGHT IRON FENCE DETAIL - N.T.S.

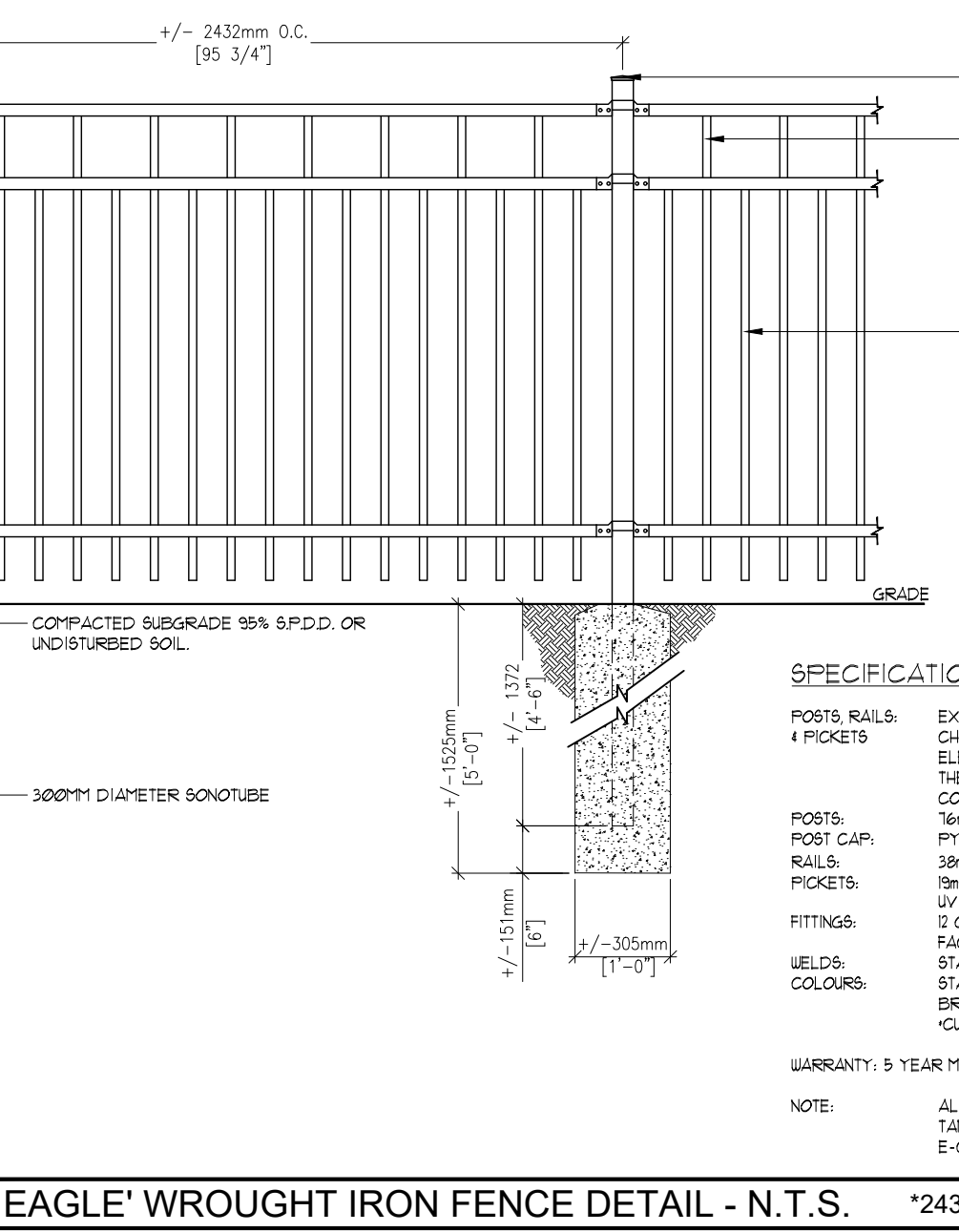

2432mm (8'-0") O.C. POST SETTING

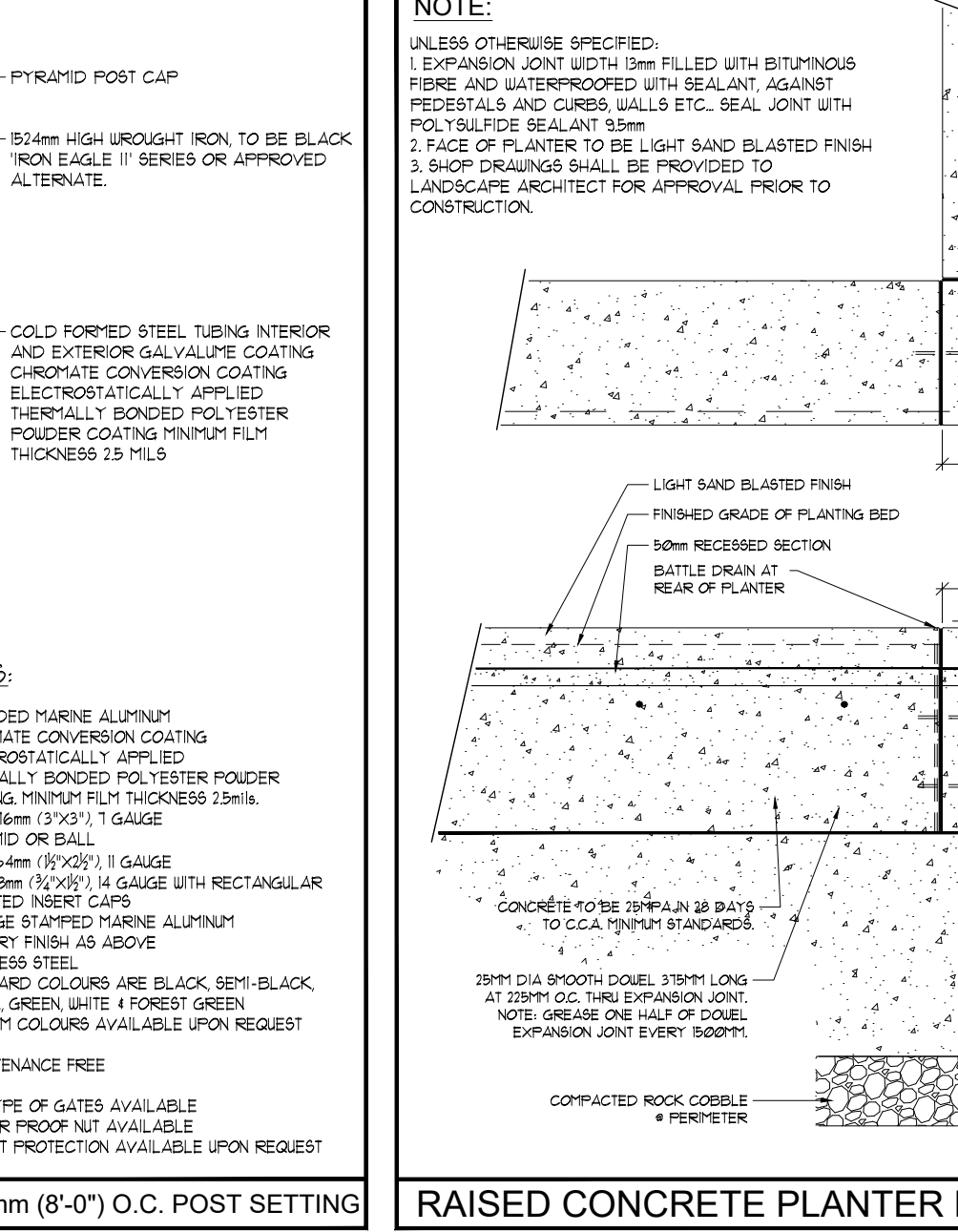

RAISED CONCRETE PLANTER DETAIL - N.T.S.

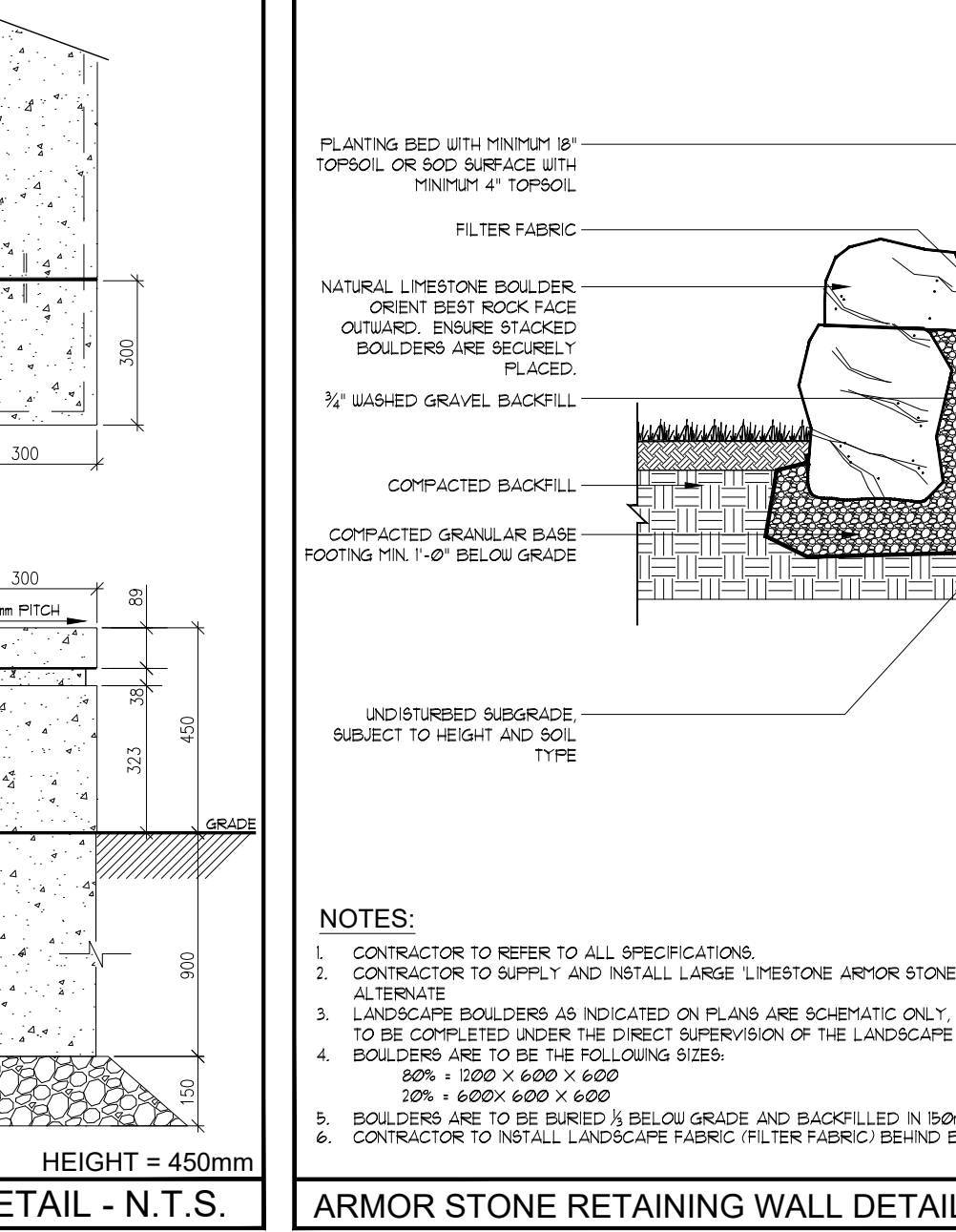

ARMOR STONE RETAINING WALL DETAIL - N.T.S.

