

# 3056 Neyagawa Boulevard

ISSUED FOR 1st OPA/ZBA SUBMISSION  
December 02, 2024

## DRAWING SCHEDULE:

SHEET	DRAWING
L-1	TPP
L-2	TPP Chart
L-3	TPP Chart Cont.
L-4	TPP Pictures
L-5	Landscape Master Plan
L-6	Tree Canopy Cover Plan
L-7	Block 1-Building 1 and Plaza Concept Plan
L-8	Block 1- Building 2 and Finger Park Concept Plan
L-9	Block 2- Building 3&4 and Landscape Concept Plan
L-10	Block 2- Building 5 and Park Concept Plan
L-11	Block 3- Building 6&7 and Finger Park Concept Plan
L-12	Streetscape & Woonerf Plan
L-13	Streetscape: Sections A & B
L-14	Streetscape: Sections C
L-15	Streetscape: Section D
L-16	Streetscape: Section E
L-17	Streetscape: Section F
L-18	Pedestrian Circulation Plan

CLIENT:  
 Neatt Communities  
 775 Main St. E  
 Milton, ON L9T 3Z3

CONSULTANT:  
**adesso design inc.**  
 landscape architecture



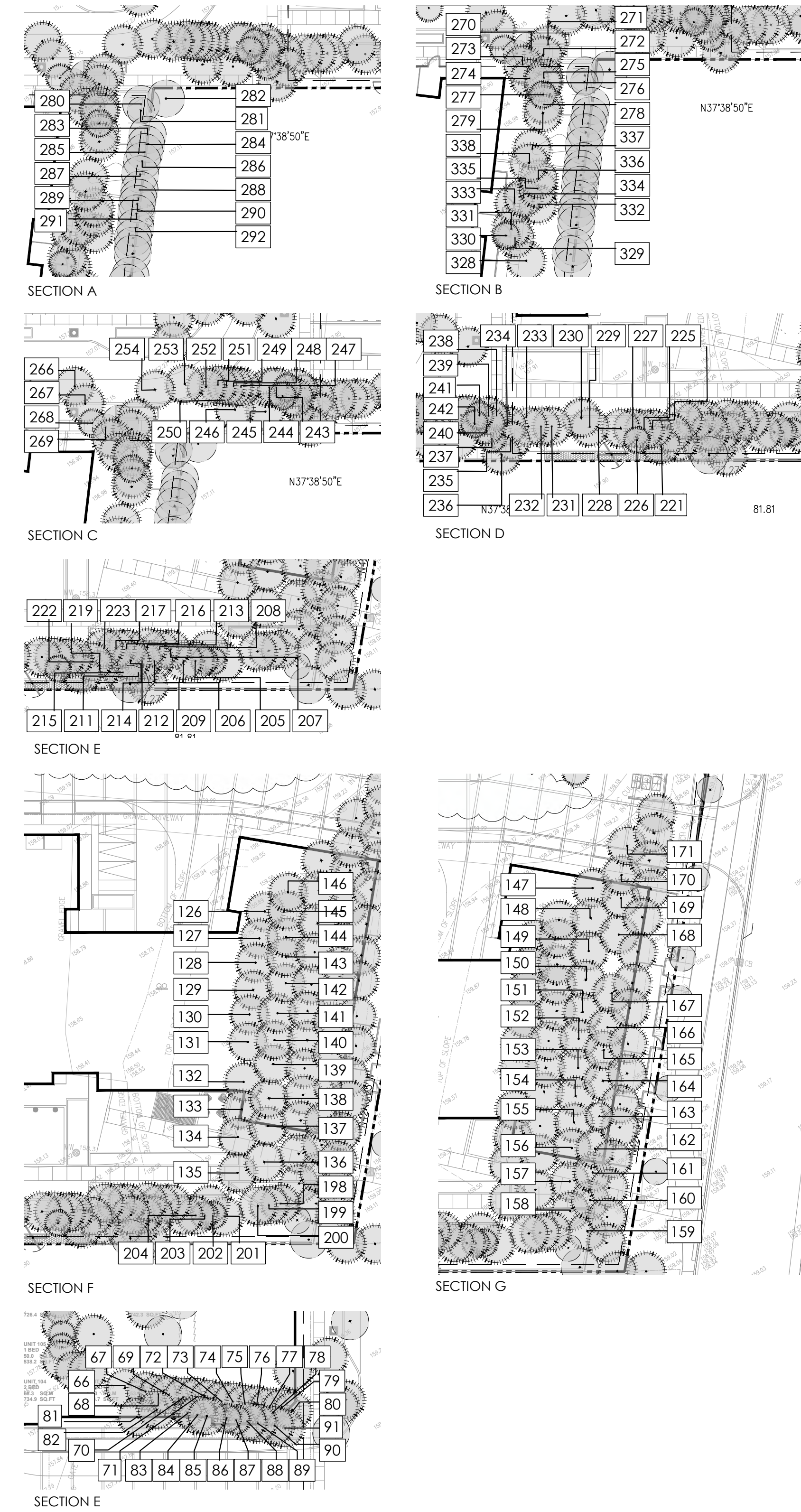
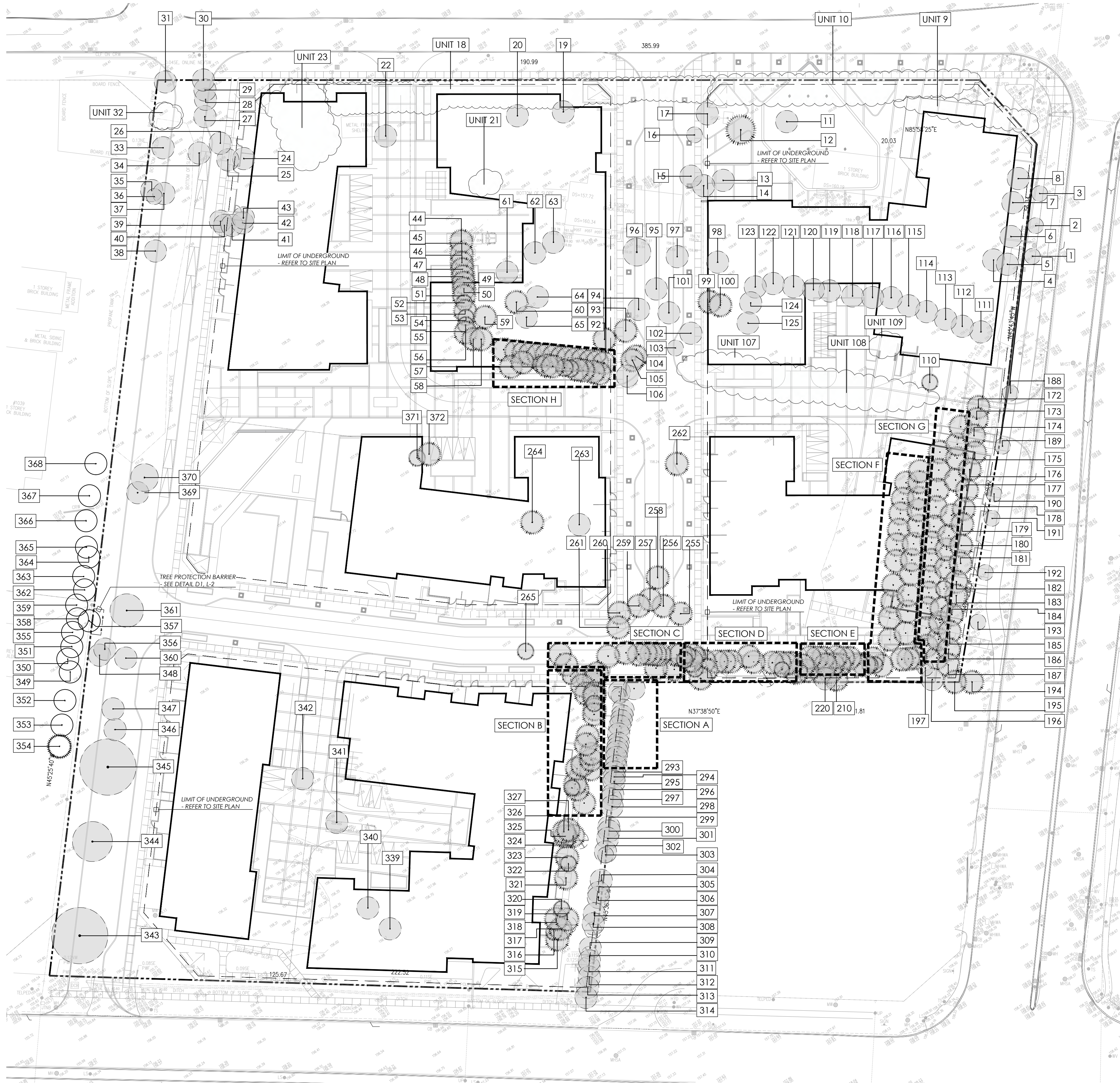
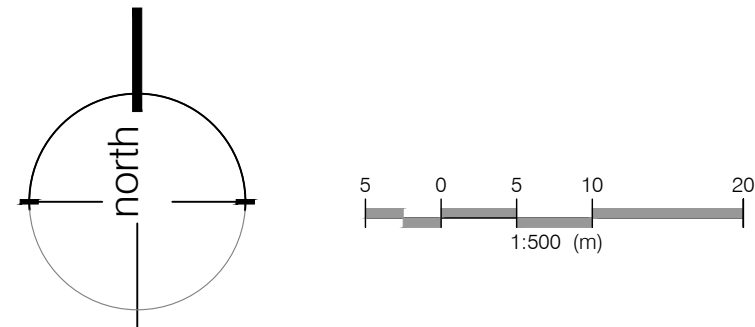

KEY MAP - N.T.S.



LEGEND

- property line
- vegetation unit (refer to chart)
- existing tree number (refer to chart)
- existing vegetation to remain
- existing vegetation to be removed
- existing dead vegetation
- existing elevations
- tree protection barrier - see detail D1, L-2

**NOT FOR CONSTRUCTION**  
ISSUED FOR REVIEW & COMMENTS ONLY

NOTE:  
Vegetation inventory undertaken by Jeremy Jackson, ISA Certified Arborist (ON-1089A) on March 14, 2024.

REVISIONS/ SUBMISSIONS

#	DATE	DESCRIPTION
1	2024-12-02	Issued for OPA/ZBA 1

STAMP



CLIENT  
Neatt Communities  
MUNICIPALITY  
Town of Oakville

PROJECT  
3056 Neyagawa Boulevard

MUNICIPAL FILE NUMBER

SHEET  
Tree Protection Plan

L-1

adesso design inc.  
landscape architecture

69 John Street South, Suite 250  
Hamilton, ON L8N 2B9  
t. 905.526.8876  
www.odesigninc.ca

EXISTING VEGETATION IDENTIFICATION TABLE

Table with columns: Tree #, Common Name, Scientific Name, DBH, T, CS, CV, DL, mI, PZ, CC, CRZ, Comments, Potential Impact from Construction, Recommendation, Ownership. Rows 1-120.

Table with columns: Tree #, Common Name, Scientific Name, DBH, T, CS, CV, DL, mI, PZ, CC, CRZ, Comments, Potential Impact from Construction, Recommendation, Ownership. Rows 121-241.

REGA Project: 2022/23-088, 3066, 3066a, 3066b, 3066c, 3066d, 3066e, 3066f, 3066g, 3066h, 3066i, 3066j, 3066k, 3066l, 3066m, 3066n, 3066o, 3066p, 3066q, 3066r, 3066s, 3066t, 3066u, 3066v, 3066w, 3066x, 3066y, 3066z

NOT FOR CONSTRUCTION ISSUED FOR REVIEW & COMMENTS ONLY

NOTE: Vegetation inventory undertaken by Jeremy Jackson, ISA Certified Arborist (ON-1089A) on March 14, 2024.

REVISIONS/ SUBMISSIONS

Table with columns: #, DATE, DESCRIPTION. Row 1: 1, 2024-12-02, Issued for OPA/ZBA 1



CLIENT Neatt Communities MUNICIPALITY Town of Oakville

PROJECT 3056 Neyagawa Boulevard

MUNICIPAL FILE NUMBER

SHEET Tree Protection Plan L-2



EXISTING VEGETATION IDENTIFICATION TABLE

Table with columns: Tree #, Common Name, Scientific Name, DBH, TI, CS, CV, DL, mPZ, CC, CRZ, Comments, Potential Impact from Construction, Recommendation, Ownership. Lists various tree species like Picea canadensis, Thuja occidentalis, and Ulmus pumila with their respective details.

Continuation of the existing vegetation identification table, listing trees like Silver Maple, Red Oak, and Eastern White Cedar.

MIGRATORY BIRDS AND NESTS:

- 1. The Owner and Contractor must be aware of the Migratory Birds Convention Act, 1994 - specifically; No tree removal or construction activity shall contravene the Act.

TREE REMOVAL:

- 1. No trees shall be removed prior to municipal approvals of the Tree Management/Tree Preservation Plan.
- 2. Note that boundary trees are protected under the Ontario Forestry Act.
- 3. Written permission from the neighbouring property owner is required prior to removal or injury of any boundary tree.

BOUNDARY TREES:

- 1. No tree removal or construction activity shall contravene the Act.
- 2. Note that boundary trees are protected under the Ontario Forestry Act.
- 3. Written permission from the neighbouring property owner is required prior to removal or injury of any boundary tree.

NOT FOR CONSTRUCTION ISSUED FOR REVIEW & COMMENTS ONLY

NOTICE: Vegetation inventory undertaken by Jeremy Jackson, ISA Certified Arborist (0N-1089A) on March 14, 2024.

Table with columns: #, DATE, DESCRIPTION. Shows a revision on 2024-12-02 for 'Issued for OPA/ZBA 1'.

CHART LEGEND/CODES

- DBH: Diameter at Breast Height (cm)
- Trunk Integrity (TI): G = Good, F = Fair, P = Poor
- Crown Structure (CS): G = Good, F = Fair, P = Poor
- Crown Vigor (CV): G = Good, F = Fair, P = Poor
- Crown Class: D = Dominant, CD = Codominant, I = Intermediate, S = Suppressed

NOTE: Written permission from the neighbouring property owner is required prior to removal or injury of any boundary tree (shared ownership) or any tree that is not fully on the subject property.

NOTES:

- 1. The area within the drip line of all existing trees shall be properly protected with temporary fencing.
- 2. The area within the protective fencing shall remain undisturbed with no construction activity, grade changes, surface treatment, compaction, or excavation.
- 3. Tree protection measures shall be installed prior to any demolition, tree removal or construction and shall remain until the completion of fine grading and sodding or seeding.

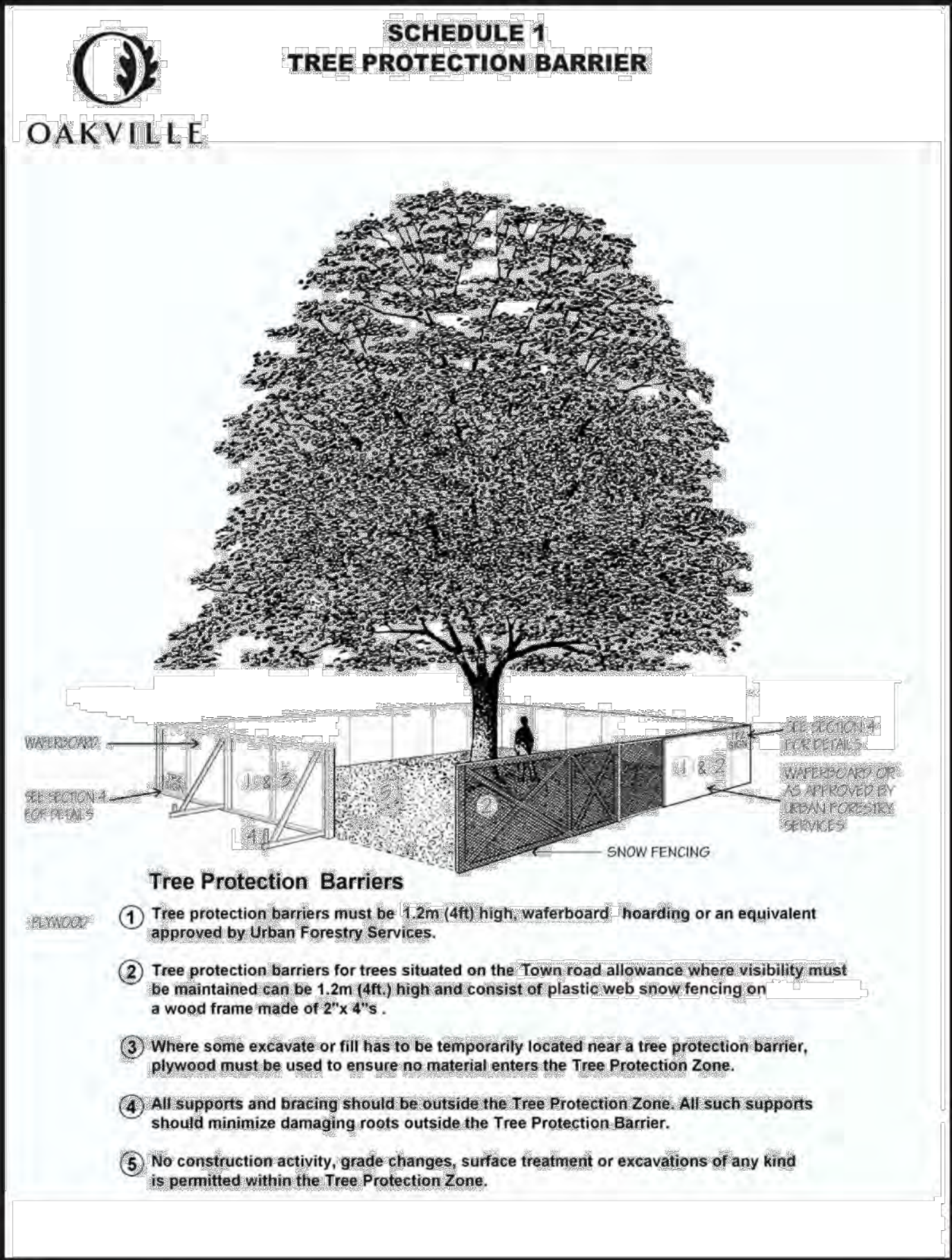

NOT FOR CONSTRUCTION ISSUED FOR REVIEW & COMMENTS ONLY

NOTICE: Vegetation inventory undertaken by Jeremy Jackson, ISA Certified Arborist (0N-1089A) on March 14, 2024.

Table with columns: #, DATE, DESCRIPTION. Shows a revision on 2024-12-02 for 'Issued for OPA/ZBA 1'.

CHART LEGEND/CODES

- DBH: Diameter at Breast Height (cm)
- Trunk Integrity (TI): G = Good, F = Fair, P = Poor
- Crown Structure (CS): G = Good, F = Fair, P = Poor
- Crown Vigor (CV): G = Good, F = Fair, P = Poor
- Crown Class: D = Dominant, CD = Codominant, I = Intermediate, S = Suppressed

NOTE: Written permission from the neighbouring property owner is required prior to removal or injury of any boundary tree (shared ownership) or any tree that is not fully on the subject property.

NOTES:

- 1. The area within the drip line of all existing trees shall be properly protected with temporary fencing.
- 2. The area within the protective fencing shall remain undisturbed with no construction activity, grade changes, surface treatment, compaction, or excavation.
- 3. Tree protection measures shall be installed prior to any demolition, tree removal or construction and shall remain until the completion of fine grading and sodding or seeding.

adesso design inc. landscape architecture

69 John Street South, Suite 250 Hamilton, ON L8N 2B9 1.905.526.8876 www.adesodesigninc.ca

L-3



Tree #1-3



Tree #4-8



Tree #13-16



Trees #25



Trees #28-30



Unit #32

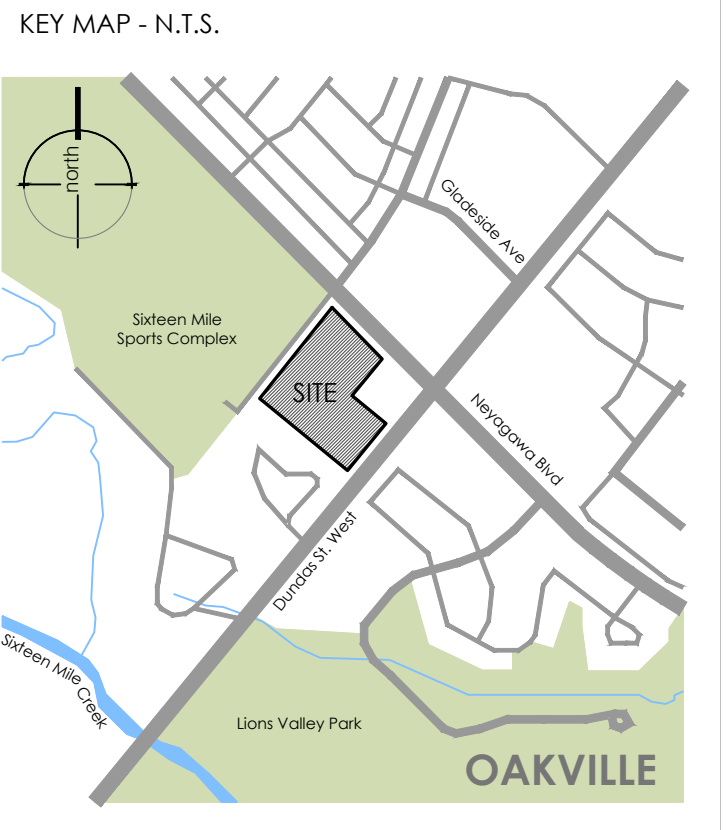

Tree #39-43



Tree #62-63



Tree #64-65



Trees #81-91



Trees #92-93



Trees #94,95,101



Tree #111,112



Tree #114-122



Tree #126-135



Trees #172-184



Trees #188-193



Trees #194,195



Tree #255-261



Tree #269-270

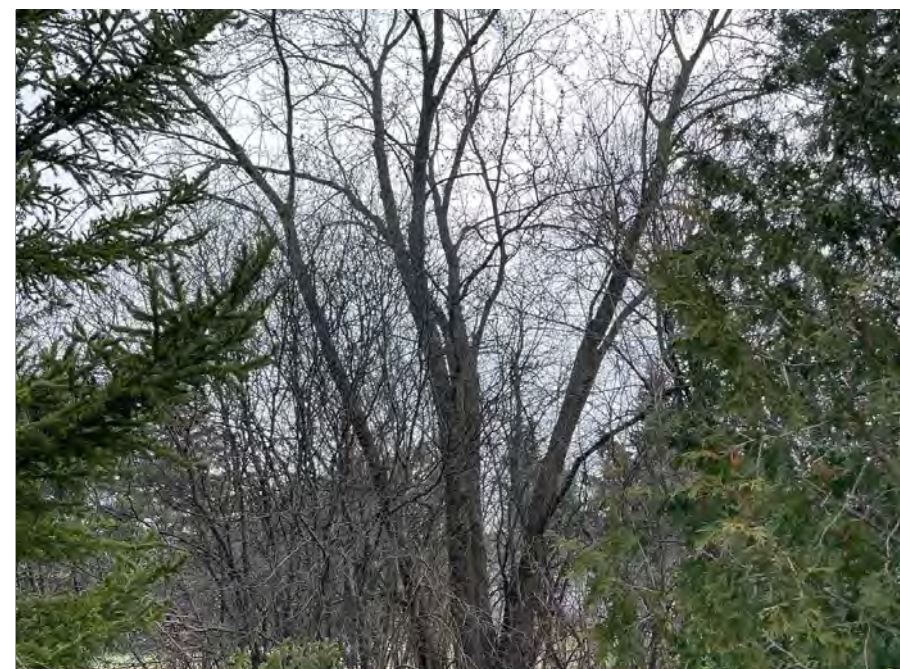

Tree #282



Trees #283-287

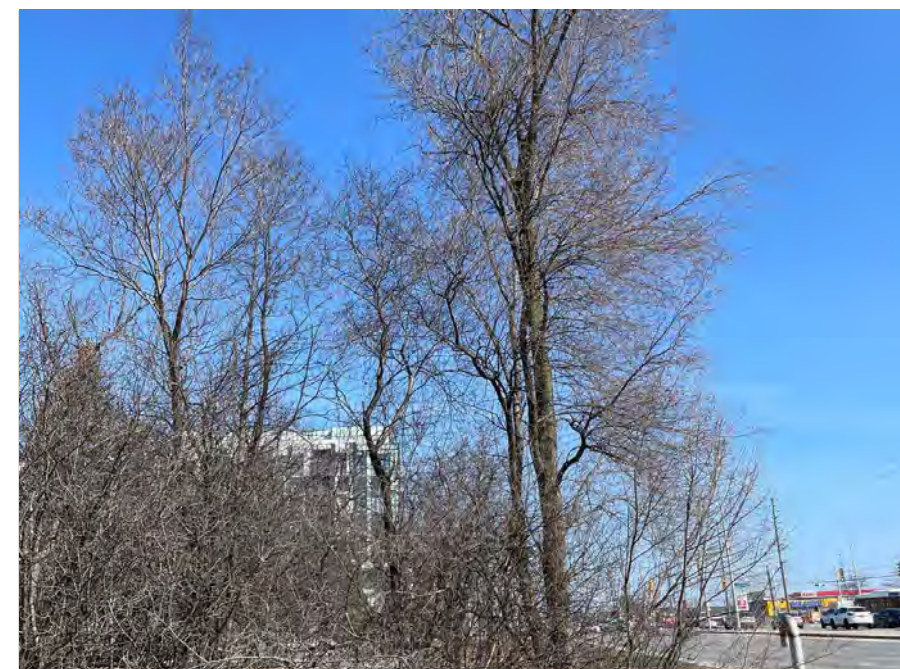

Trees #312-314



Trees #315-337



Tree #339,340



Tree #343

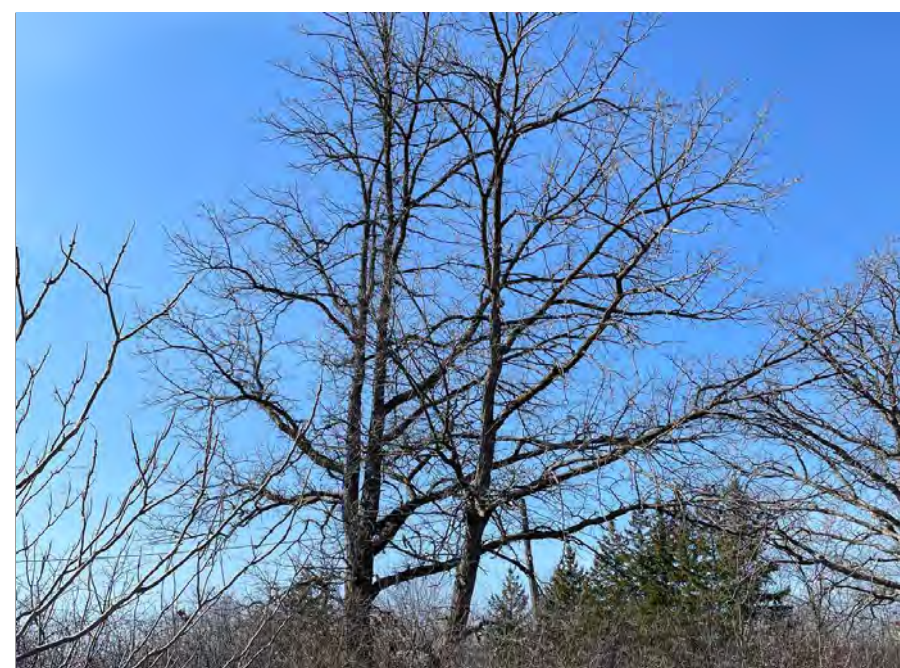

Tree #344

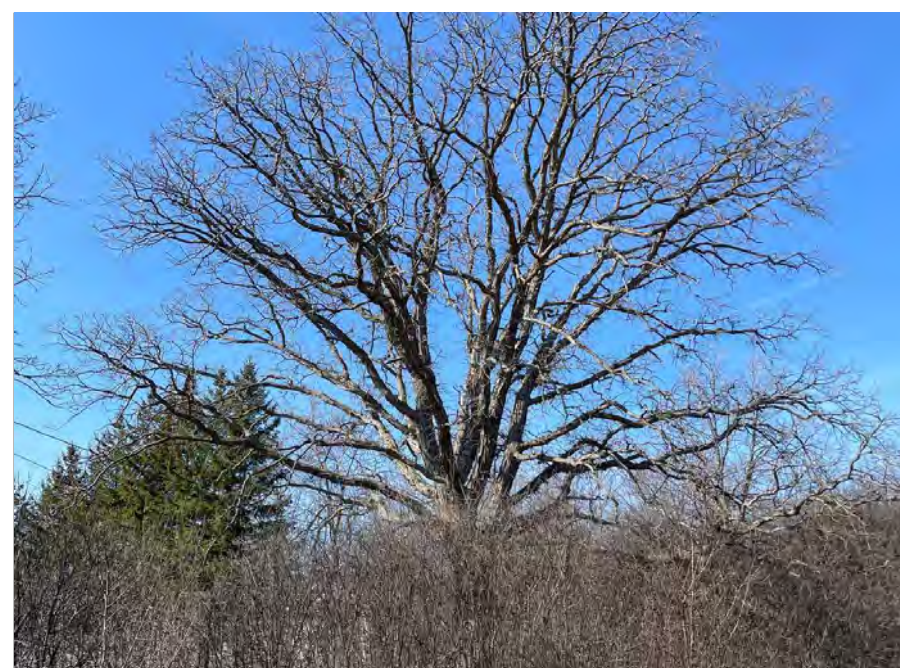

Trees #345

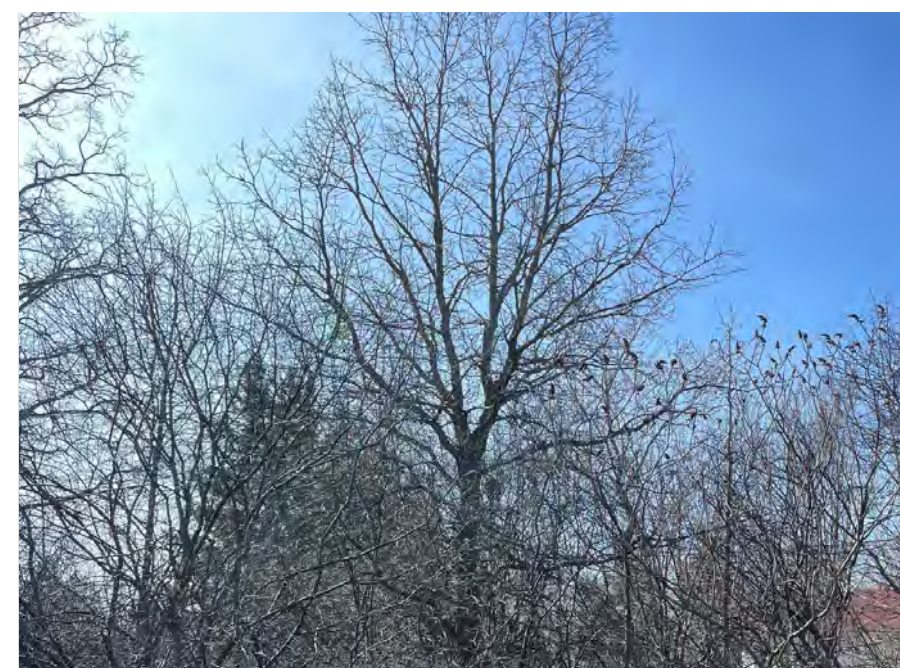

Trees #347



Trees #349-351

NOT FOR CONSTRUCTION  
ISSUED FOR REVIEW & COMMENTS ONLY

NOTE:  
Vegetation inventory undertaken by Jeremy Jackson, ISA Certified Arborist (ON-1089A) on March 14, 2024.

REVISIONS/ SUBMISSIONS

#	DATE	DESCRIPTION
1	2024-12-02	Issued for OPA/ZBA 1



CLIENT  
Neatt Communities

MUNICIPALITY  
Town of Oakville

PROJECT  
3056 Neyagawa Boulevard

MUNICIPAL FILE NUMBER

SHEET  
Tree Protection Plan **L-4**

adesso design inc.  
landscape architecture

69 John Street South, Suite 250  
Hamilton, ON L8N 2B9  
t. 905.526.8876  
www.adesoesigninc.ca

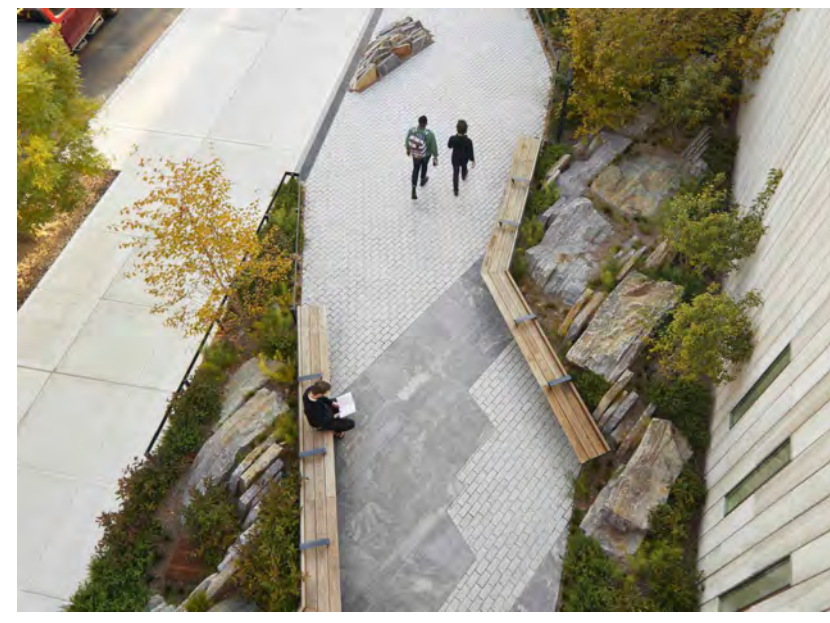
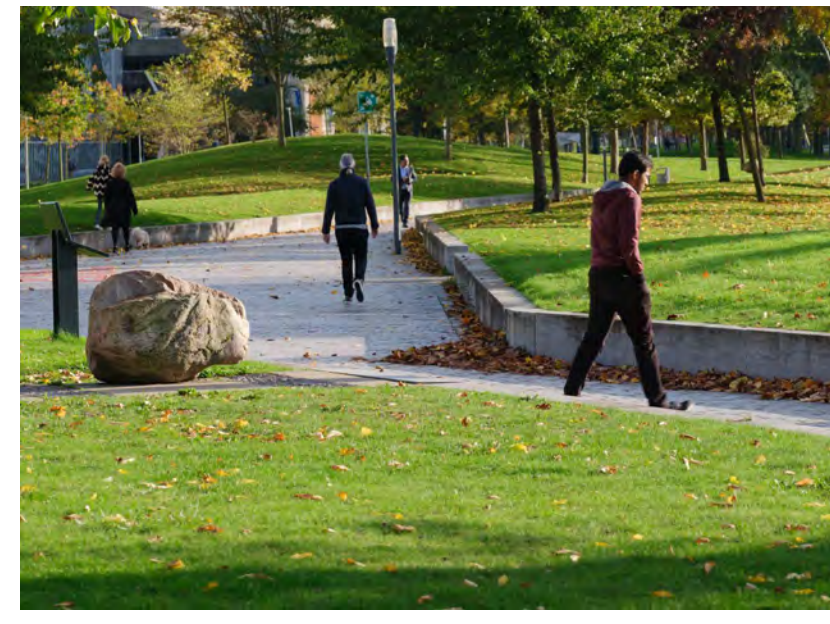
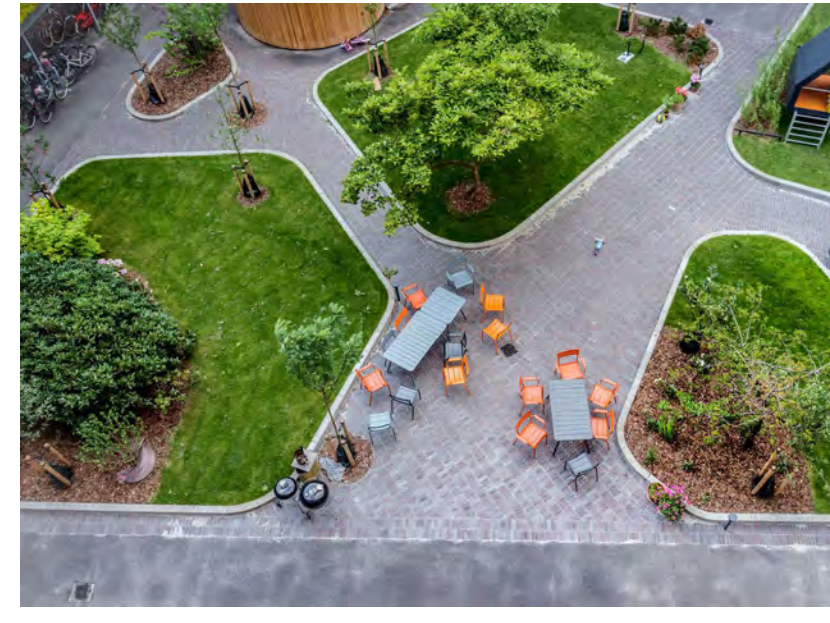
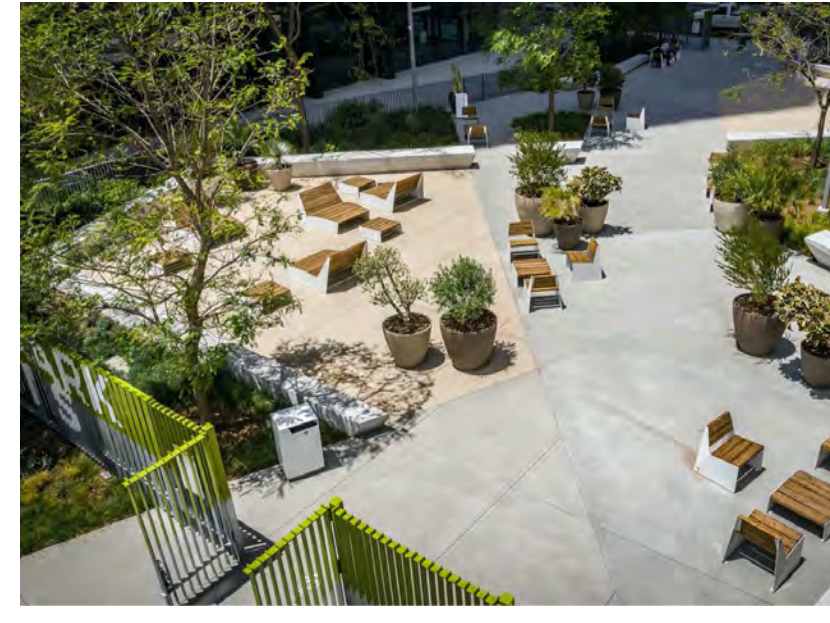
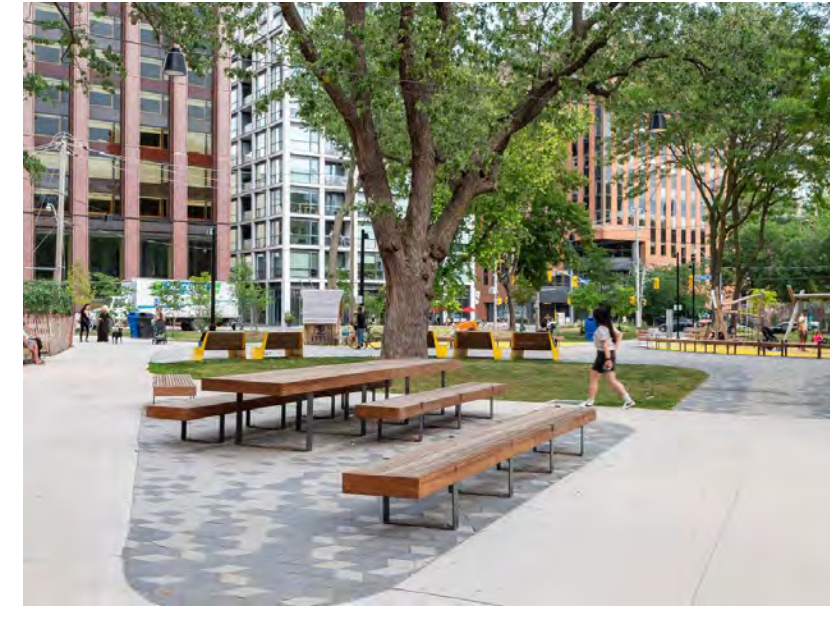

KEY MAP - N.T.S.

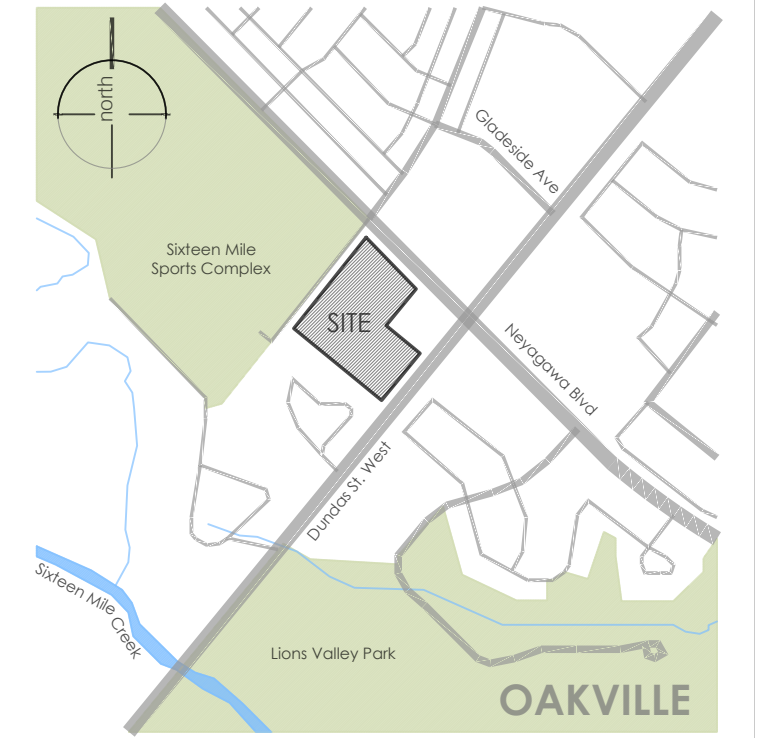

- LEGEND
- property line
  - existing tree to remain
  - proposed deciduous tree
  - proposed shrub
  - proposed perennial
  - min. 150mm topsoil, fine grade & sod
  - C.I.P. concrete
  - precast concrete unit pavers
  - proposed light standard

NOT FOR CONSTRUCTION  
ISSUED FOR REVIEW & COMMENTS ONLY

REVISIONS/ SUBMISSIONS

#	DATE	DESCRIPTION
1	2024-12-02	Issued for OPA/ZBA 1



CLIENT  
Neatt Communities

MUNICIPALITY  
Oakville

PROJECT  
3056 Neyagawa Boulevard  
Oakville, ON

MUNICIPAL FILE NUMBER

SHEET  
Overall  
Landscape Plan

L-5

adesso design inc.  
landscape architecture

69 John Street South, Suite 250  
Hamilton, ON L8N 2B9  
T. 905.526.8876  
www.adesodesigninc.ca

RECA Project: 2024-12-02 10:00 AM Neatt Communities 3056 Neyagawa Blvd, Oakville, ON L8N 2B9  
 LAST SAVED BY: J. B. B. 2024-12-02 10:00 AM PROJECTED BY: J. B. B. 2024-12-02 10:00 AM

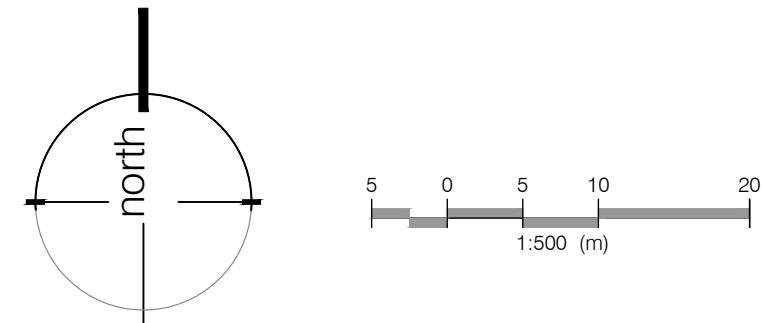

KEY MAP - N.T.S.

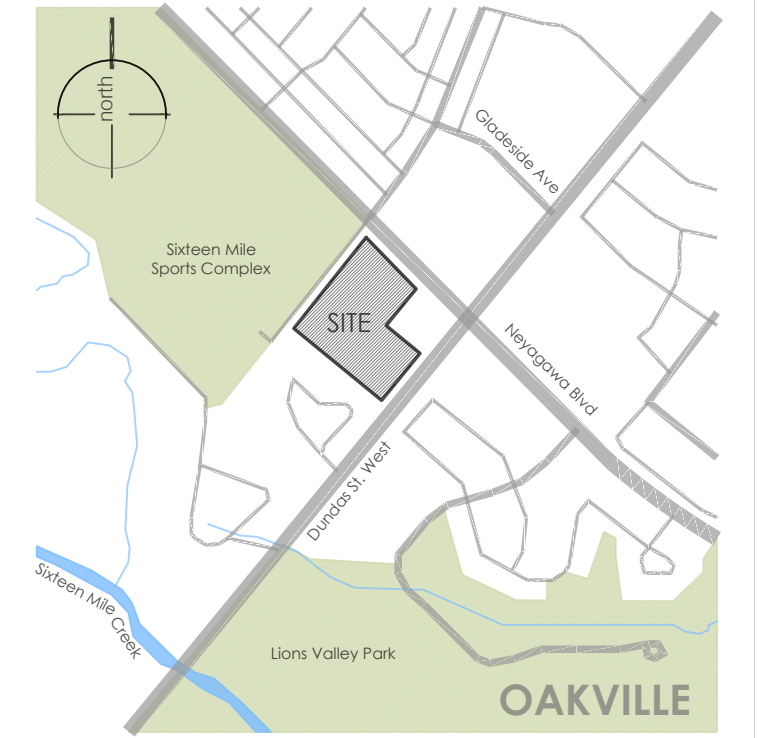

LEGEND

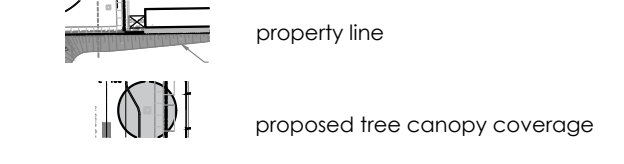

NOT FOR CONSTRUCTION  
ISSUED FOR REVIEW & COMMENTS ONLY

REVISIONS/ SUBMISSIONS

#	DATE	DESCRIPTION
1	2024-12-02	Issued for OPA/ZBA 1

STAMP



CLIENT  
Neatt Communities

MUNICIPALITY  
Oakville

PROJECT  
3056 Neyagawa Boulevard  
Oakville, ON

MUNICIPAL FILE NUMBER

SHEET  
Tree Canopy  
Cover Plan

L-6

adesso design inc.  
landscape architecture

69 John Street South, Suite 250  
Hamilton, ON L8N 2B9  
t. 905.526.8876  
www.adesodesigninc.ca

Canopy Cover Chart

Tree #	Species (Botanical Name)	Number of Trees	Soil Volume (meters cubed) per tree	Crown Area (meters squared) per tree	Canopy Area Subtotal (meters squared)
Proposed Large Stature Trees (14+m spread)					
1-5	<i>Quercus palustris</i>	5	30.00	138.20	691.00
6-11	<i>Tilia americana</i>	6	38.00	153.00	918.00
12-17	<i>Ginkgo biloba</i>	6	33.03	156.00	936.00
18-23	<i>Tilia americana</i>	6	38.00	153.00	918.00
24-28	<i>Quercus rubra</i>	5	41.00	144.50	722.50
94-101	<i>Ulmus x 'Pioneer'</i>	8	30.00	142.57	1140.56
Proposed Medium Stature Trees (10 - 13m spread)					
35-36	<i>Acer rubrum</i>	2	30.00	78.50	157.00
37-39	<i>Gleditsia triacanthos f. inermis</i>	3	37.44	78.50	235.50
40-49	<i>Liriodendron tulipifera 'arnold'</i>	10	35.00	78.50	785.00
50-54	<i>Acer rubrum</i>	5	30.00	78.50	392.50
55-58	<i>Gleditsia triacanthos f. inermis</i>	4	37.44	78.50	314.00
59-62	<i>Tilia americana 'Redmond'</i>	4	37.44	78.50	314.00
63-67 & 102	<i>Acer rubrum</i>	6	30.00	78.50	471.00
68-71	<i>Gleditsia triacanthos f. inermis</i>	4	37.44	78.50	314.00
72-74	<i>Tilia americana 'Redmond'</i>	3	37.44	78.50	235.50
75-78	<i>Acer rubrum</i>	4	37.44	78.50	314.00
79-82	<i>Gleditsia triacanthos f. inermis</i>	3	37.44	78.50	235.50
83-88	<i>Tilia americana 'Redmond'</i>	6	37.44	78.50	471.00
89-93	<i>Liriodendron tulipifera 'arnold'</i>	5	42.00	78.50	392.50
Proposed Small Stature Trees (3-9m spread)					
29-34	<i>Syringa rectilata</i>	6	30.00	7.00	42.00
TOTAL TREES		101		TOTAL CANOPY (sq. m.)	9999.56
Canopy Summary					
Net Site Area (sq m.)		37461.00			
Site Canopy Coverage (%)		26.69%			
Land Use Canopy Cover Target (%)		20.00%			

ALAO Project: 2023-22-088, 3056 Neyagawa Blvd, Oakville, ON L8N 2B9. Drawn by: J. D. 2024-12-02. 100% (100% of the project area). Project: 2023-22-088, 3056 Neyagawa Blvd, Oakville, ON L8N 2B9. Drawn by: J. D. 2024-12-02. 100% (100% of the project area).







KEY MAP

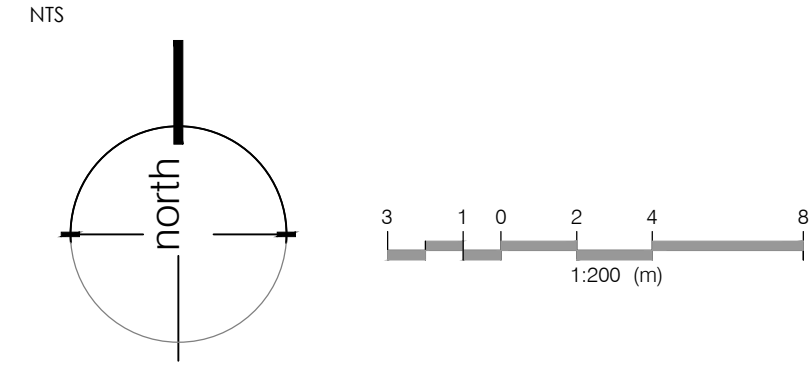

KEY MAP - N.T.S.



LEGEND

- property line
- existing tree to remain
- proposed deciduous tree
- proposed shrub
- proposed perennial
- min. 150mm topsoil, fine grade & sod
- C.I.P. concrete
- precast concrete unit pavers
- proposed light standard

**NOT FOR CONSTRUCTION**  
ISSUED FOR REVIEW & COMMENTS ONLY

REVISIONS/ SUBMISSIONS

#	DATE	DESCRIPTION
1	2024-12-02	Issued for OPA/ZBA 1



CLIENT  
Neatt Communities

MUNICIPALITY  
Oakville

PROJECT  
3056 Neyagawa Boulevard  
Oakville, ON

MUNICIPAL FILE NUMBER

SHEET  
Block 1/ Building 2 and  
Finger Park Concept  
Plan

adesso design inc.  
landscape architecture

69 John Street South, Suite 250  
Hamilton, ON L8N 2B9  
t. 905.526.8876  
www.adessodesigninc.ca

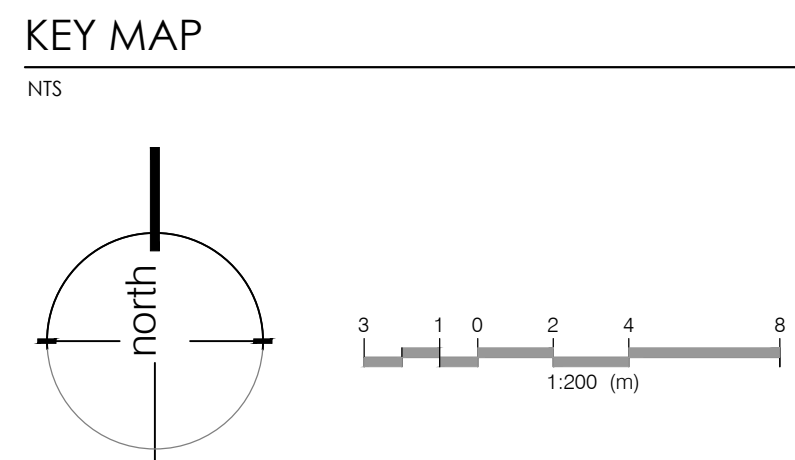

- LEGEND
- property line
  - ⊕ existing tree to remain
  - ⊕ proposed deciduous tree
  - ⊕ proposed shrub
  - ⊕ proposed perennial
  - ▭ min. 150mm topsoil, fine grade & sod
  - ▭ C.I.P. concrete
  - ▭ precast concrete unit pavers
  - ⊕ proposed light standard

- PRIVATE TERRACES
- RAMP TO UNDERGROUND PARKING
- SHORT TERM PARKING
- BOLLARDS
- SHORT TERM PARKING
- BIKE RACKS
- WOODEN BENCHES
- 900MM RAISED METAL PLANTERS

NOT FOR CONSTRUCTION  
ISSUED FOR REVIEW & COMMENTS ONLY

REVISIONS/ SUBMISSIONS

#	DATE	DESCRIPTION
1	2024-12-02	Issued for OPA/ZBA 1

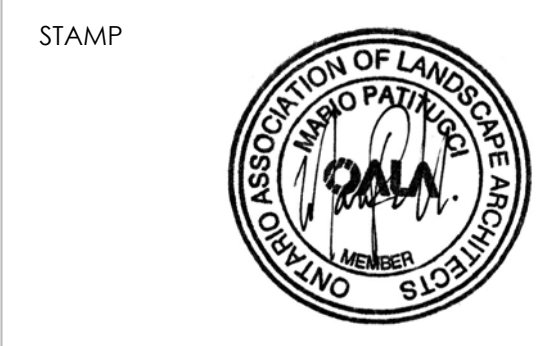

CLIENT  
Neatt Communities

MUNICIPALITY  
Oakville

PROJECT  
3056 Neyogawa Boulevard  
Oakville, ON

MUNICIPAL FILE NUMBER

SHEET  
Block 2/Buildings 3 & 4  
Concept Plan

adesso design inc.  
landscape architecture

69 John Street South, Suite 250  
Hamilton, ON L8N 2B9  
1.905.526.8876  
www.adessodesigninc.ca

ELSA Project: Block 2/Buildings 3 & 4 Concept Plan, December 2, 2024  
 LAST REVISED BY: M. Neatt, December 2, 2024  
 LAST APPROVED BY: M. Neatt, December 2, 2024  
 LAST APPROVED BY: M. Neatt, December 2, 2024



KEY MAP

NTS

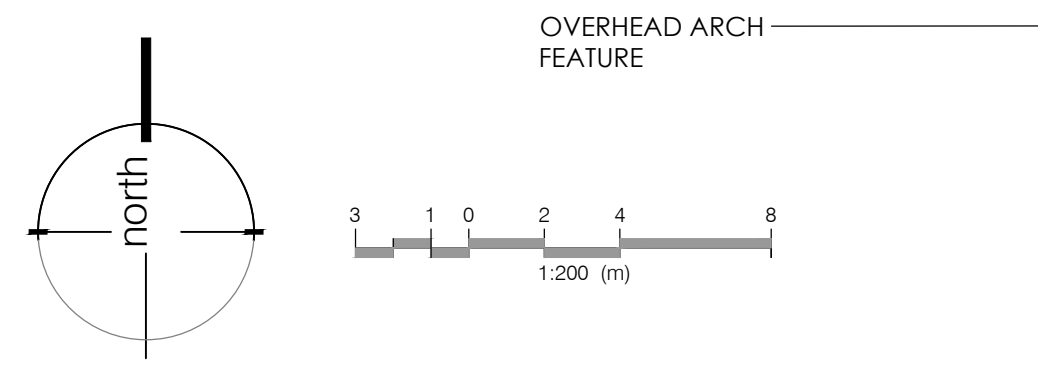

- OVERHEAD ARCH FEATURE
- RESIDENTIAL OUTDOOR AMENITY
- PLAYGROUND
- SHADE STRUCTURE WITH BENCHES BELOW
- TOT LOT PLAYGROUND
- CLOUD SEATS
- LAWN AREA



LEGEND

- property line
- existing tree to remain
- proposed deciduous tree
- proposed shrub
- proposed perennial
- min. 150mm topsoil, fine grade & sod
- C.I.P. concrete
- precast concrete unit pavers
- proposed light standard

NOT FOR CONSTRUCTION  
ISSUED FOR REVIEW & COMMENTS ONLY

REVISIONS/ SUBMISSIONS

#	DATE	DESCRIPTION
1	2024-12-02	Issued for OPA/ZBA 1

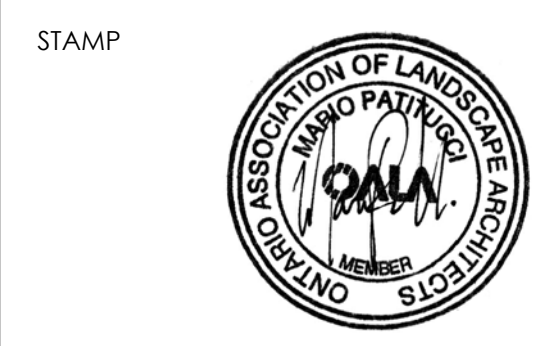

CLIENT  
Neatt Communities

MUNICIPALITY  
Oakville

PROJECT  
3056 Neyagawa Boulevard  
Oakville, ON

MUNICIPAL FILE NUMBER

SHEET  
Block 2 / Building 5  
Park Concept Plan

L-10

adesso design inc.  
landscape architecture

69 John Street South, Suite 250  
Hamilton, ON L8N 2B9  
1.905.526.8876  
www.adessodesigninc.ca



PLAYGROUND PRECEDENTS



KEY MAP

NTS

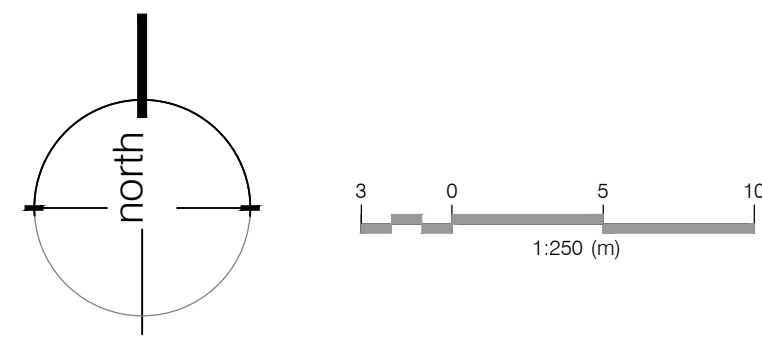

KEY MAP - N.T.S.

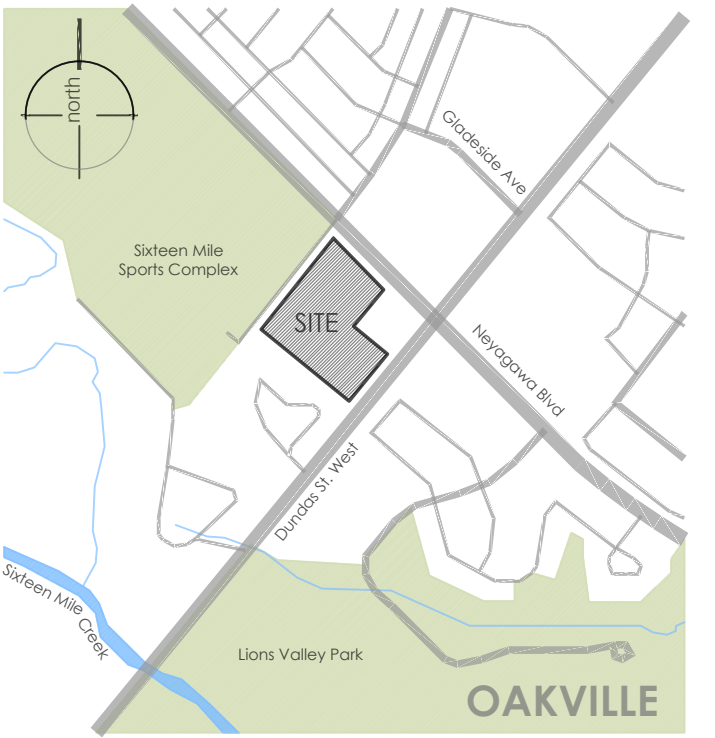

LEGEND

- property line
- existing tree to remain
- proposed deciduous tree
- proposed shrub
- proposed perennial
- min. 150mm topsoil, fine grade & sod
- C.I.P. concrete
- precast concrete unit pavers
- proposed light standard

**NOT FOR CONSTRUCTION**  
ISSUED FOR REVIEW & COMMENTS ONLY

REVISIONS/ SUBMISSIONS

#	DATE	DESCRIPTION
1	2024-12-02	Issued for OPA/ZBA 1

STAMP



CLIENT  
Neatt Communities

MUNICIPALITY  
Oakville

PROJECT  
3056 Neyagawa Boulevard  
Oakville, ON

MUNICIPAL FILE NUMBER

SHEET  
Block 3 / Buildings 6 & 7  
and Finger Park  
Concept Plan

L-11

adesso design inc.  
landscape architecture

69 John Street South, Suite 250  
Hamilton, ON L8N 2B9  
t. 905.526.8876  
www.adessodesigninc.ca

FUTURE EXTENSION OF SIXTEEN MILE DRIVE

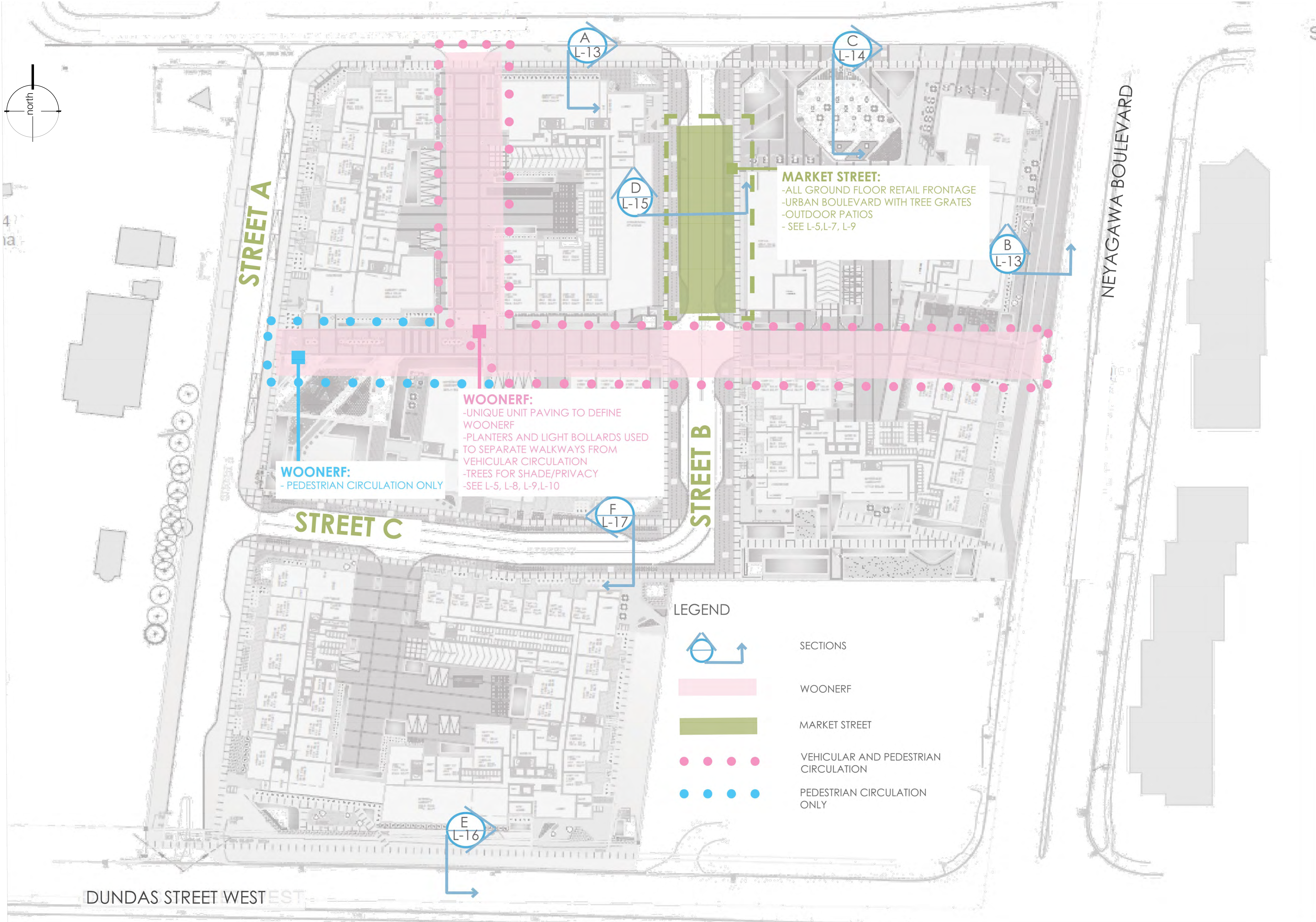

**WOONERF:**  
 -UNIQUE UNIT PAVING TO DEFINE WOONERF  
 -PLANTERS AND LIGHT BOLLARDS USED TO SEPARATE WALKWAYS FROM VEHICULAR CIRCULATION  
 -TREES FOR SHADE/PRIVACY  
 -SEE L-5, L-8, L-9, L-10

**WOONERF:**  
 - PEDESTRIAN CIRCULATION ONLY

**MARKET STREET:**  
 -ALL GROUND FLOOR RETAIL FRONTAGE  
 -URBAN BOULEVARD WITH TREE GRATES  
 -OUTDOOR PATIOS  
 -SEE L-5, L-7, L-9

LEGEND

- SECTIONS
- WOONERF
- MARKET STREET
- VEHICULAR AND PEDESTRIAN CIRCULATION
- PEDESTRIAN CIRCULATION ONLY

KEY MAP - N.T.S.

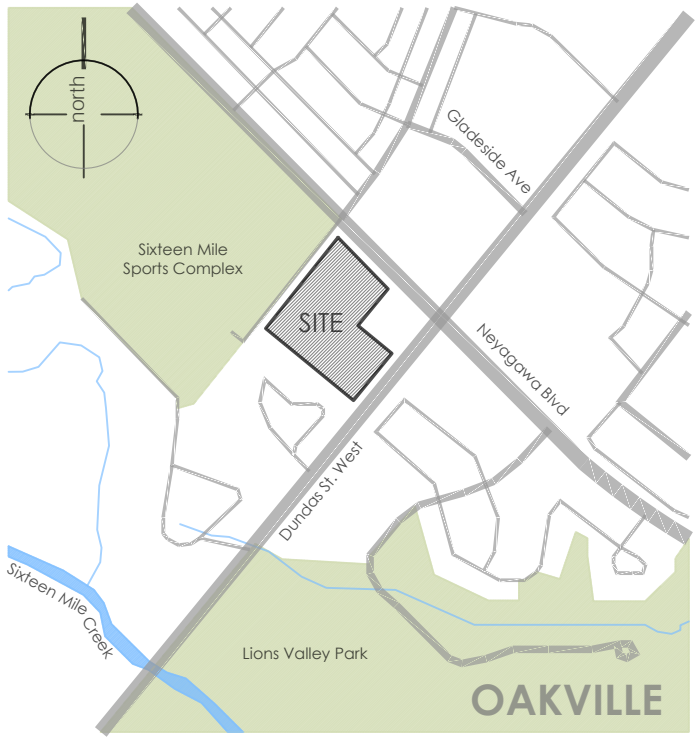

**NOT FOR CONSTRUCTION**  
 ISSUED FOR REVIEW & COMMENTS ONLY

#	DATE	DESCRIPTION
1	2024-12-02	Issued for OPA/ZBA 1



CLIENT  
 Neatt Communities  
 MUNICIPALITY  
 Oakville

PROJECT  
 3056 Neyagawa Boulevard  
 Oakville, ON

MUNICIPAL FILE NUMBER

SHEET  
 Streetscape / Woonerf Landscape Plan **L-12**

adesso design inc.  
 landscape architecture

69 John Street South, Suite 250  
 Hamilton, ON L8N 2B9  
 t. 905.526.8876  
 www.odesigninc.ca

REGA Project: 2022-088 - 3056 Neyagawa Blvd, Oakville, ON  
 Project Name: Streetscape / Woonerf Landscape Plan  
 Project Number: 2022-088  
 Date: December 2, 2024 11:28:51 AM  
 Project Location: 3056 Neyagawa Blvd, Oakville, ON L8N 2B9



KEY MAP  
SCALE NTS

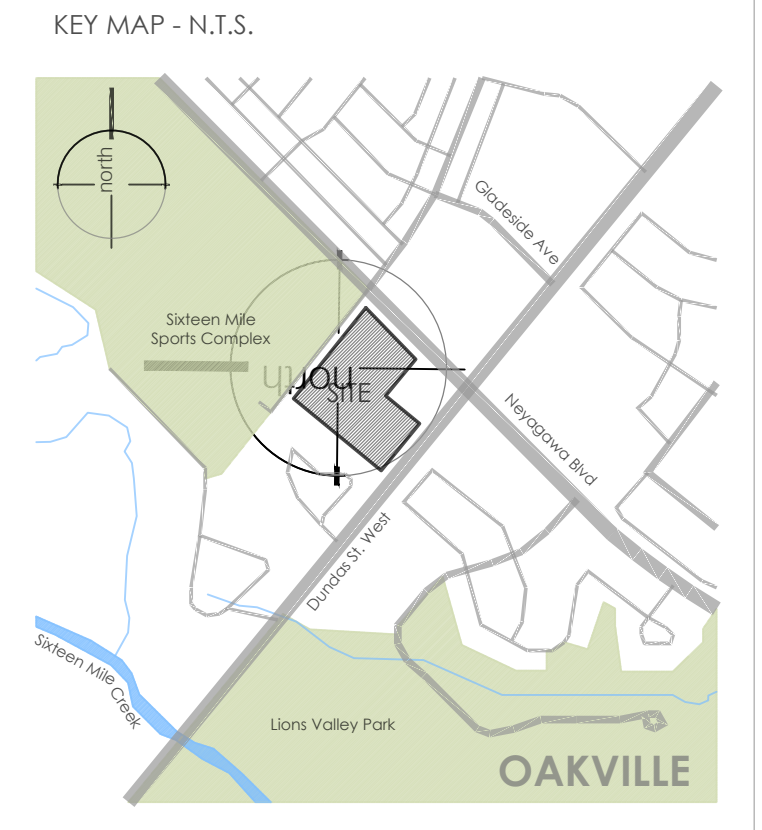
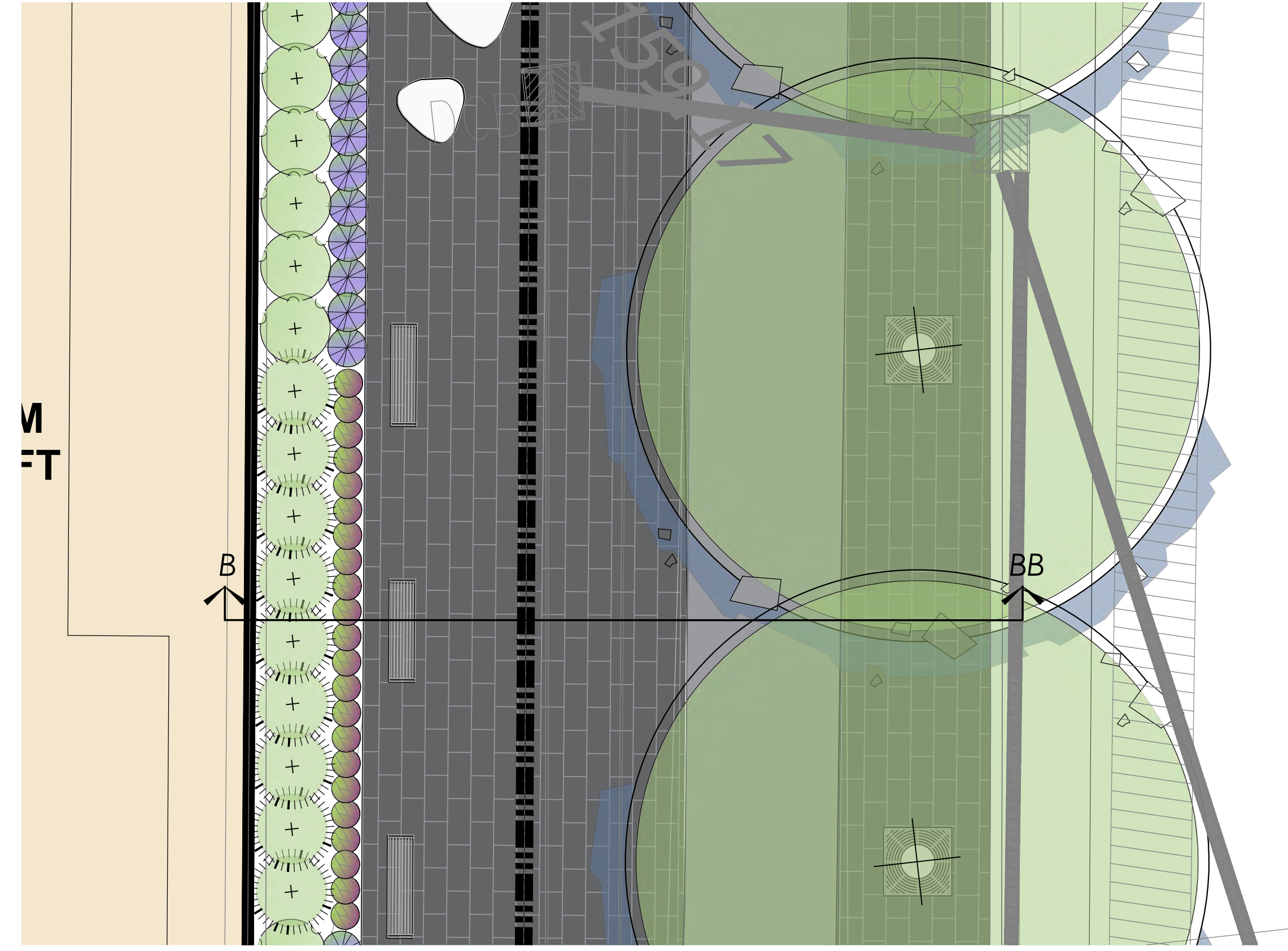
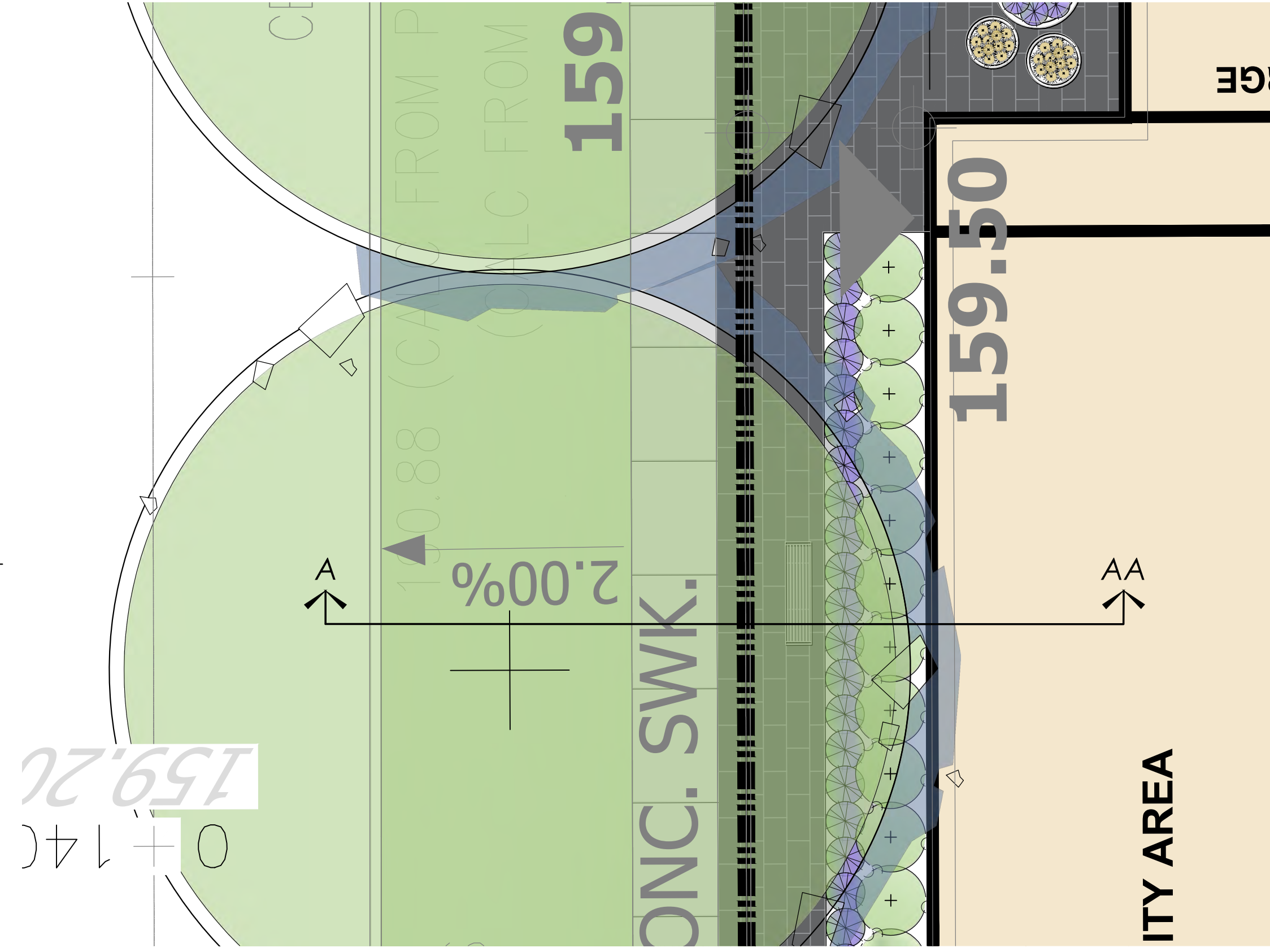
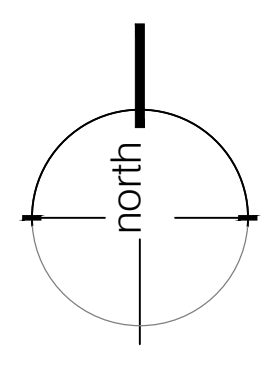

- LEGEND
- property line
  - existing tree to remain
  - proposed deciduous tree
  - proposed shrub
  - proposed perennial
  - min. 150mm topsoil, fine grade & sod
  - C.I.P. concrete
  - precast concrete unit pavers
  - proposed light standard

NOT FOR CONSTRUCTION  
ISSUED FOR REVIEW & COMMENTS ONLY

REVISIONS/ SUBMISSIONS

#	DATE	DESCRIPTION
1	2024-12-02	Issued for OPA/ZBA 1



CLIENT  
Neatt Communities  
MUNICIPALITY  
Oakville  
PROJECT  
3056 Neyagawa Boulevard  
Oakville, ON  
MUNICIPAL FILE NUMBER

SHEET  
Section A+B

adesso design inc.  
landscape architecture

69 John Street South, Suite 250  
Hamilton, ON L8N 2B9  
t. 905.526.8876  
www.adesodesigninc.ca

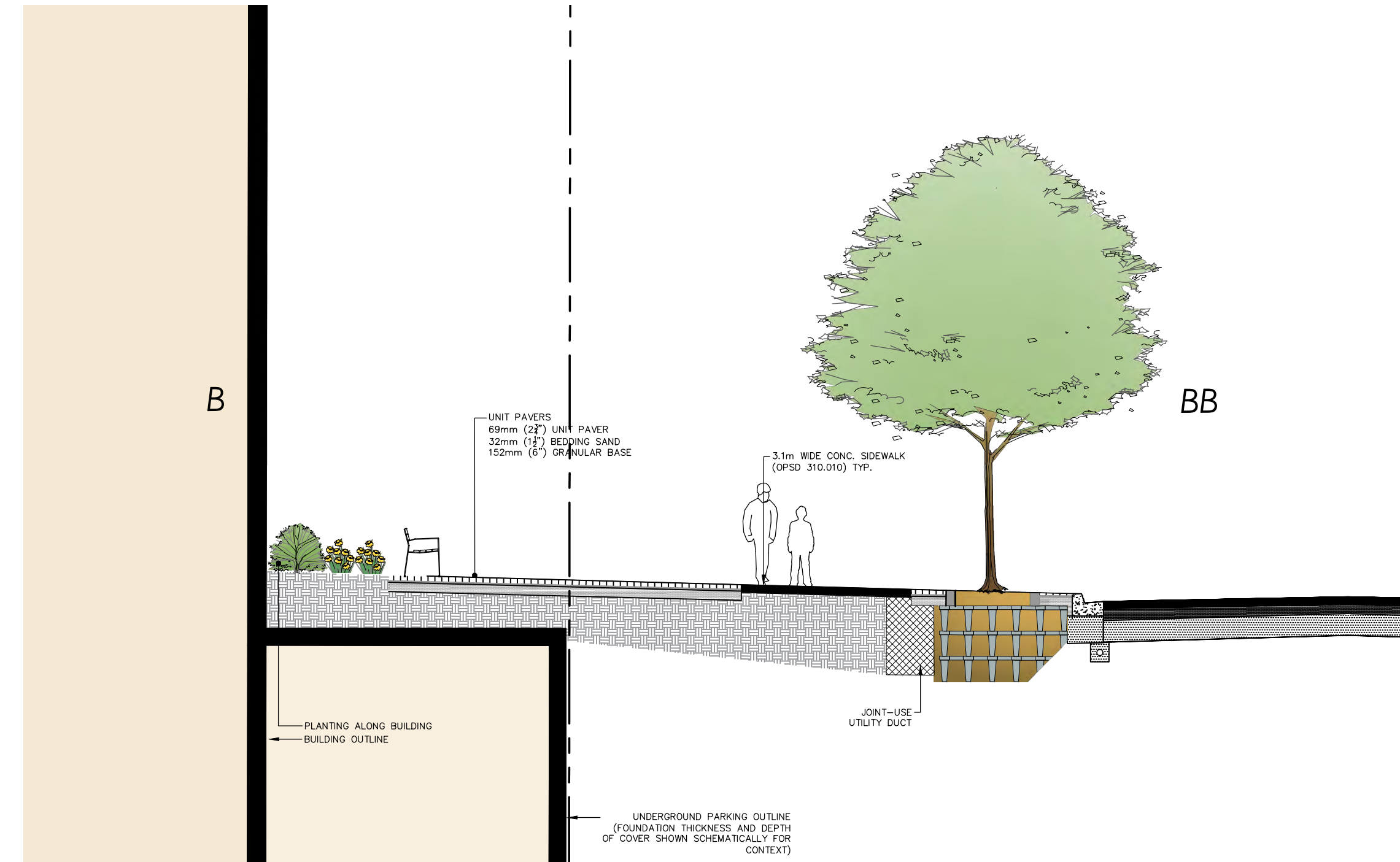
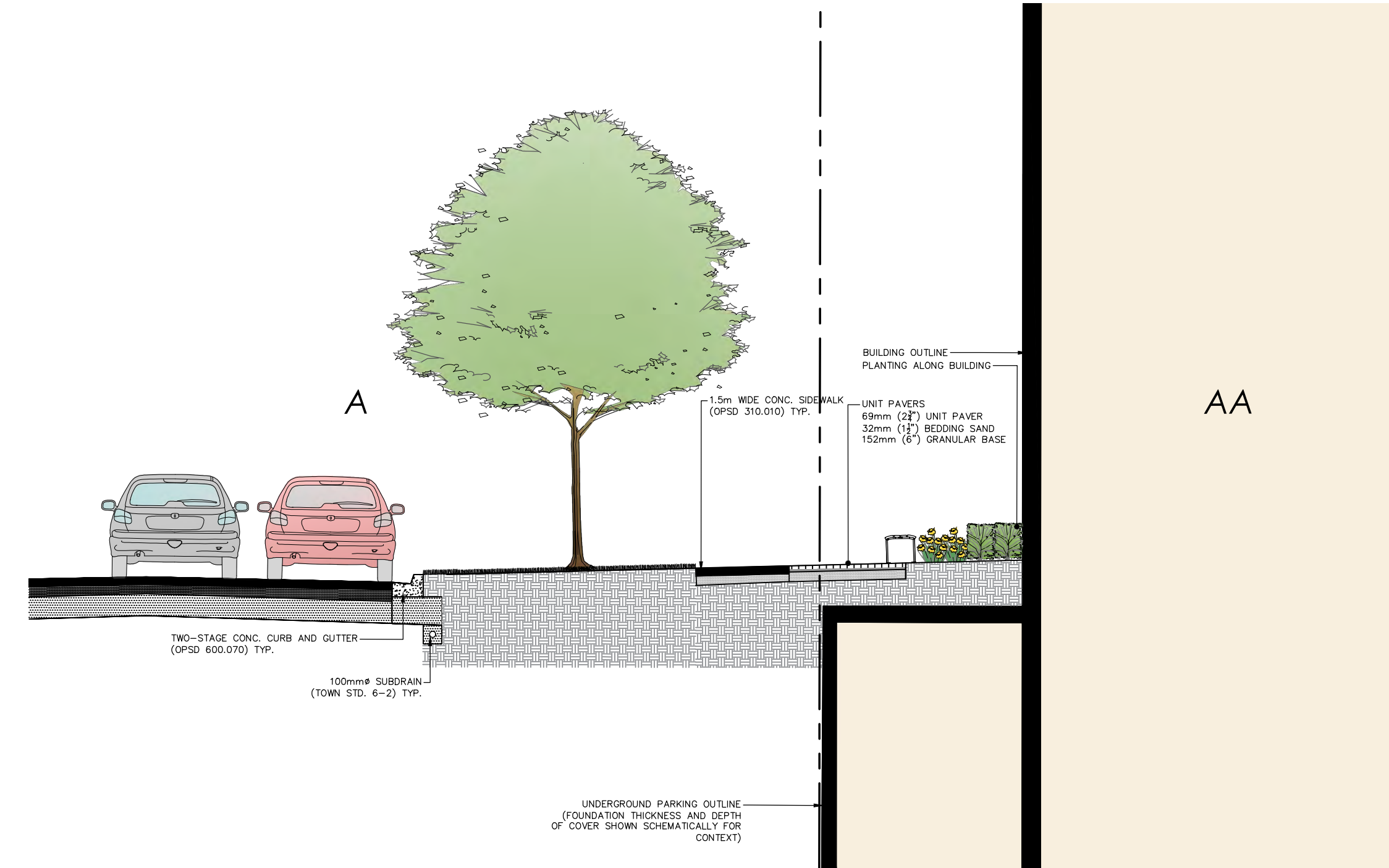

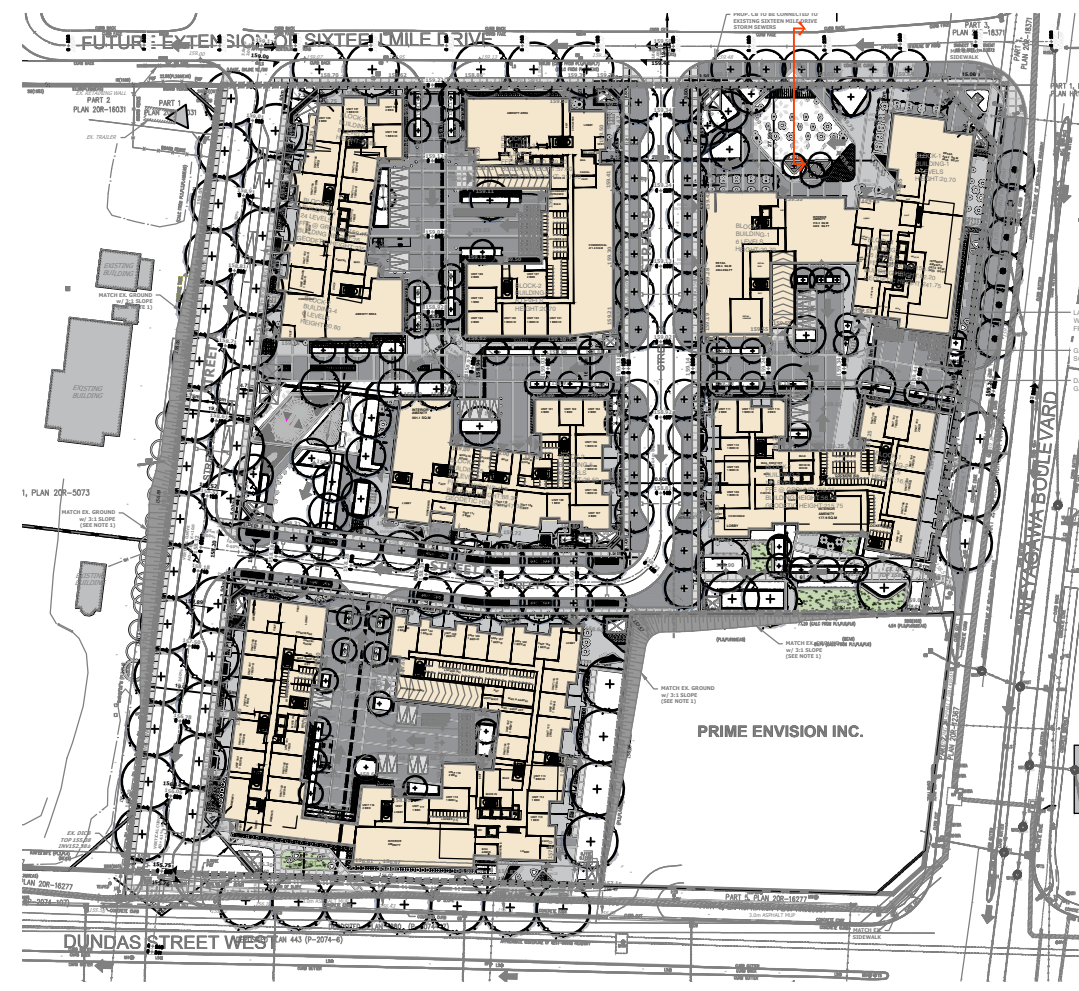

KEY MAP

SCALE N/T.S.

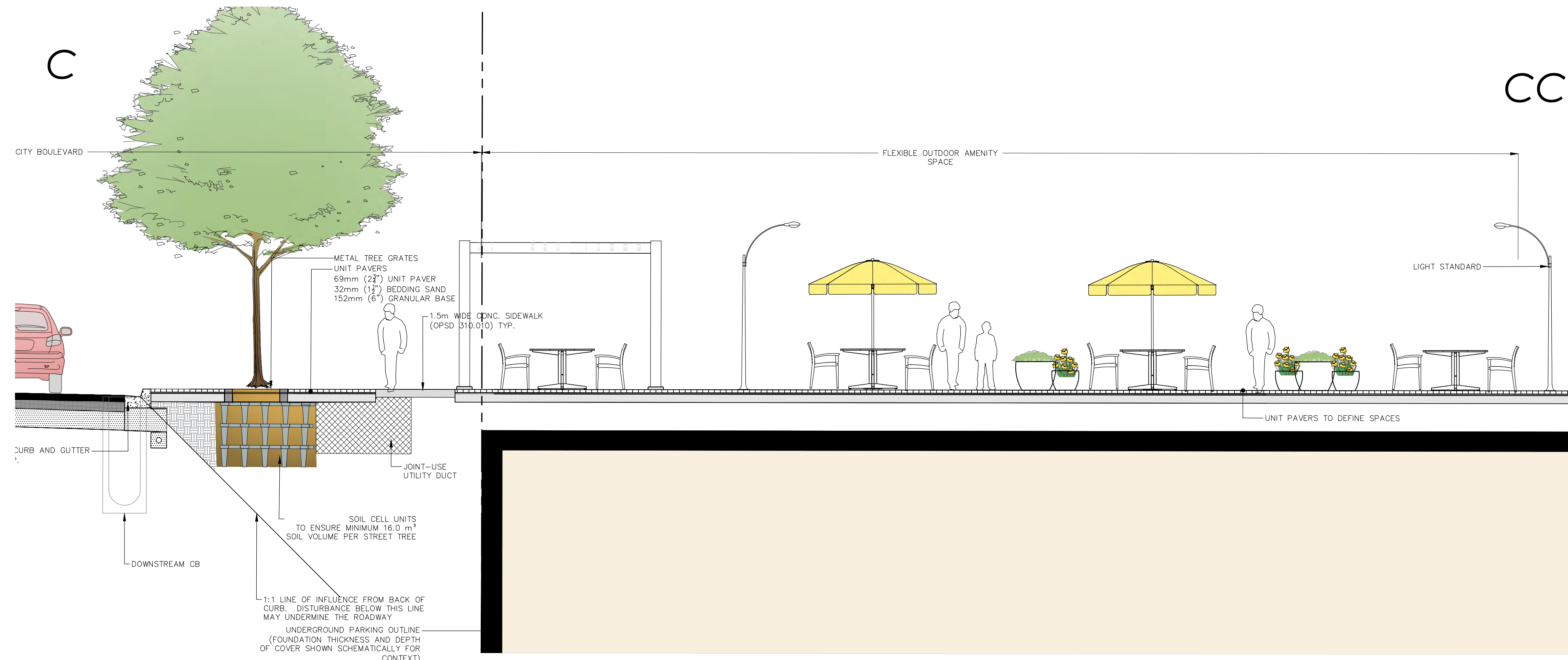
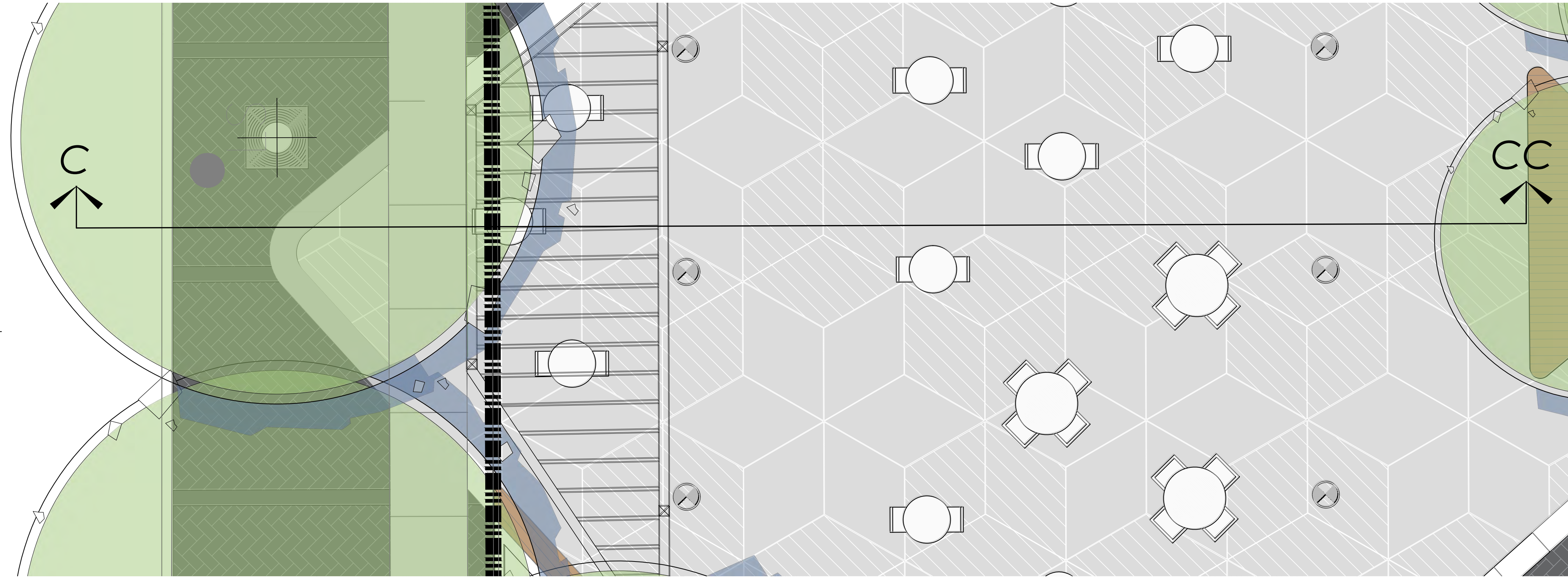
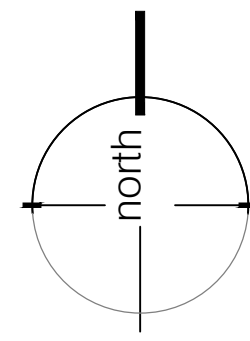

KEY MAP - N.T.S.

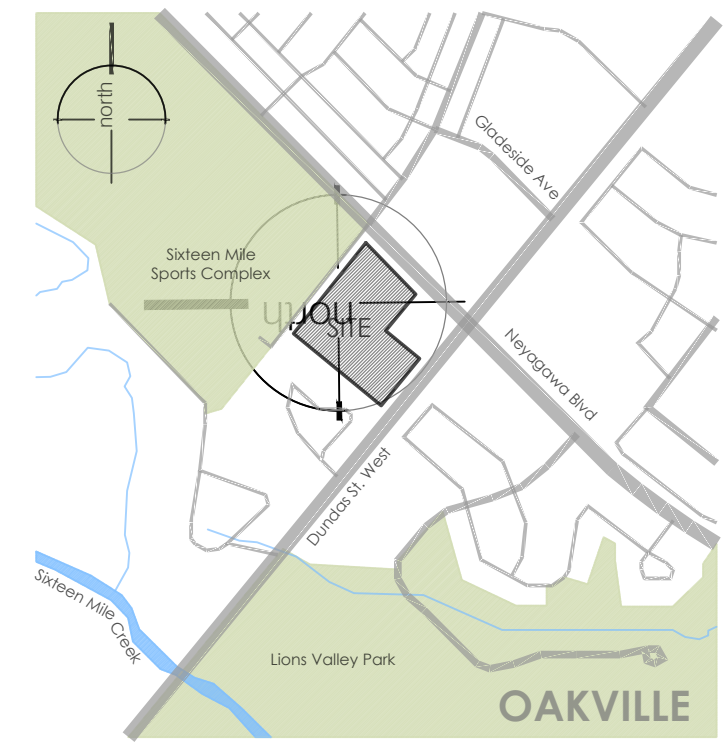

LEGEND

- property line
- existing tree to remain
- proposed deciduous tree
- proposed shrub
- proposed perennial
- min. 150mm topsoil, fine grade & sod
- C.I.P. concrete
- precast concrete unit pavers
- proposed light standard

NOT FOR CONSTRUCTION  
ISSUED FOR REVIEW & COMMENTS ONLY

REVISIONS/ SUBMISSIONS

#	DATE	DESCRIPTION
1	2024-12-02	Issued for OPA/ZBA 1

STAMP



CLIENT  
Neatt Communities

MUNICIPALITY  
Oakville

PROJECT  
3056 Neyagawa Boulevard  
Oakville, ON

MUNICIPAL FILE NUMBER

SHEET  
Section C

L-14

adesso design inc.  
landscape architecture

69 John Street South, Suite 250  
Hamilton, ON L8N 2B9  
t. 905.526.8876  
www.adessodesigninc.ca

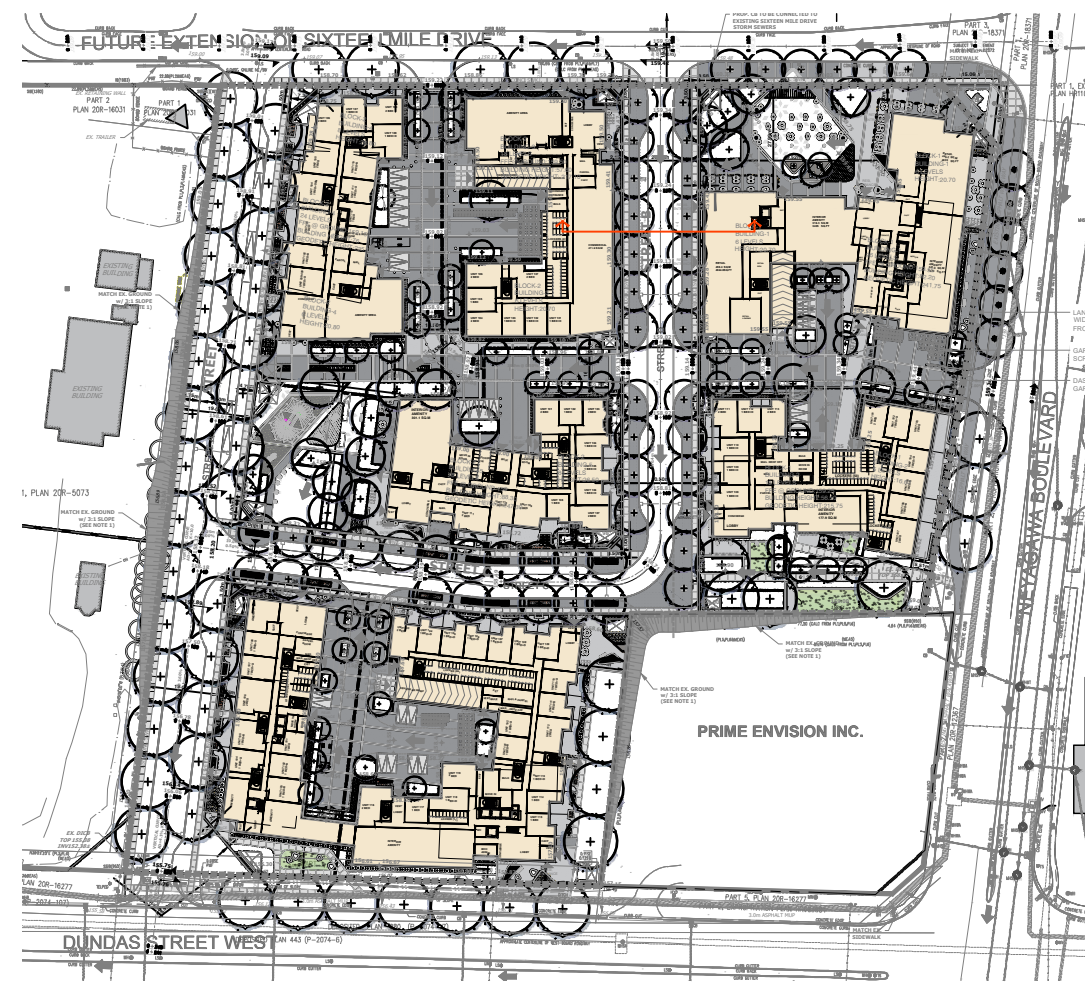

KEY MAP

SCALE NTS

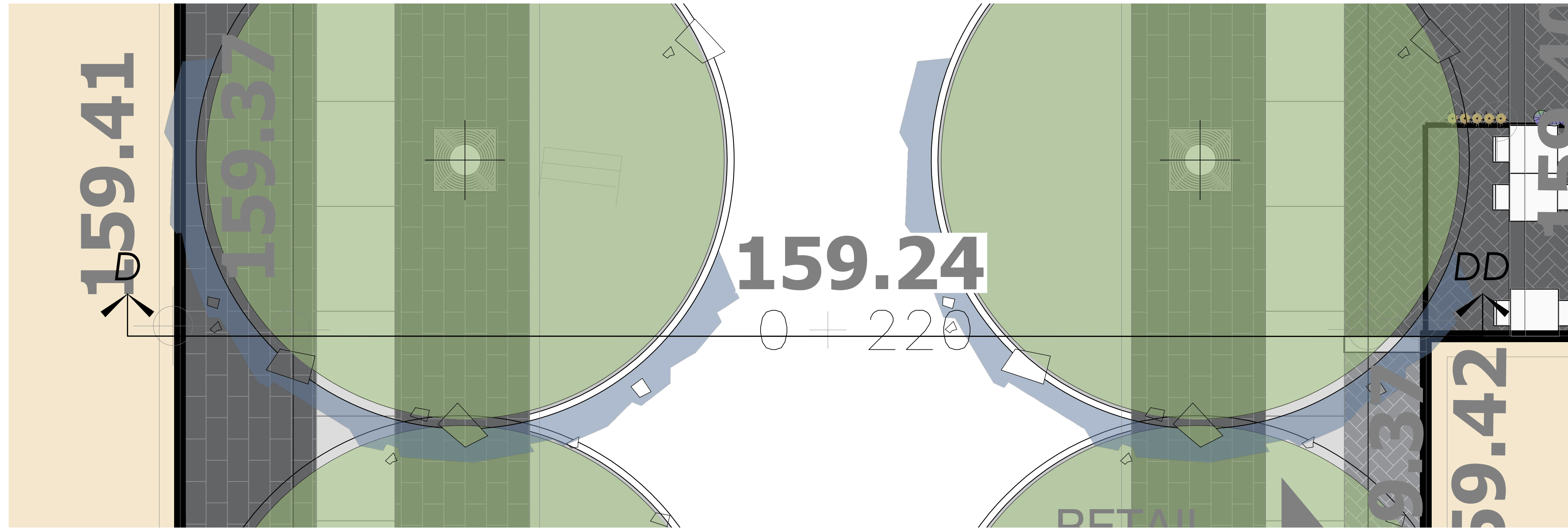
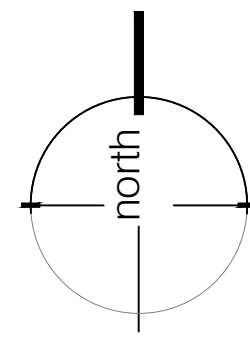

KEY MAP - N.T.S.

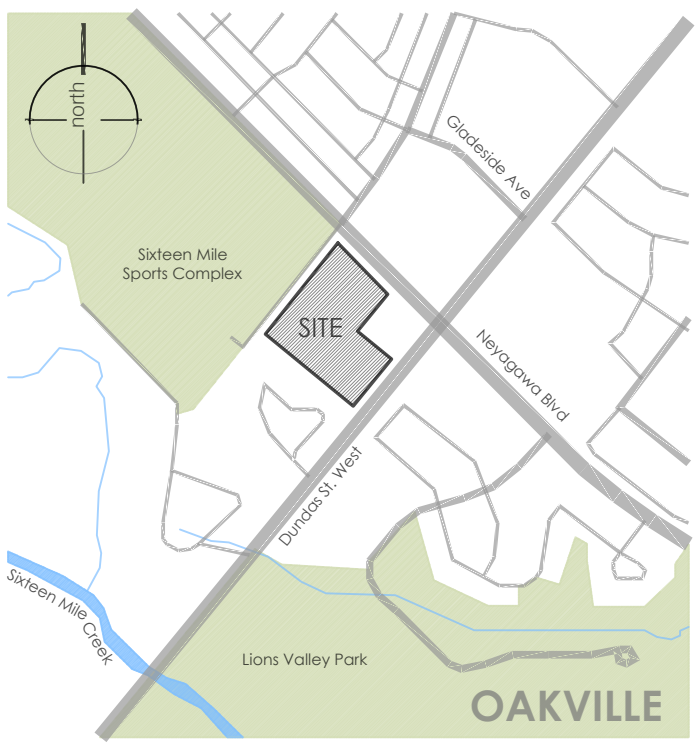

LEGEND

- property line
- existing tree to remain
- proposed deciduous tree
- proposed shrub
- proposed perennial
- min. 150mm topsoil, fine grade & sod
- C.I.P. concrete
- precast concrete unit pavers
- proposed light standard

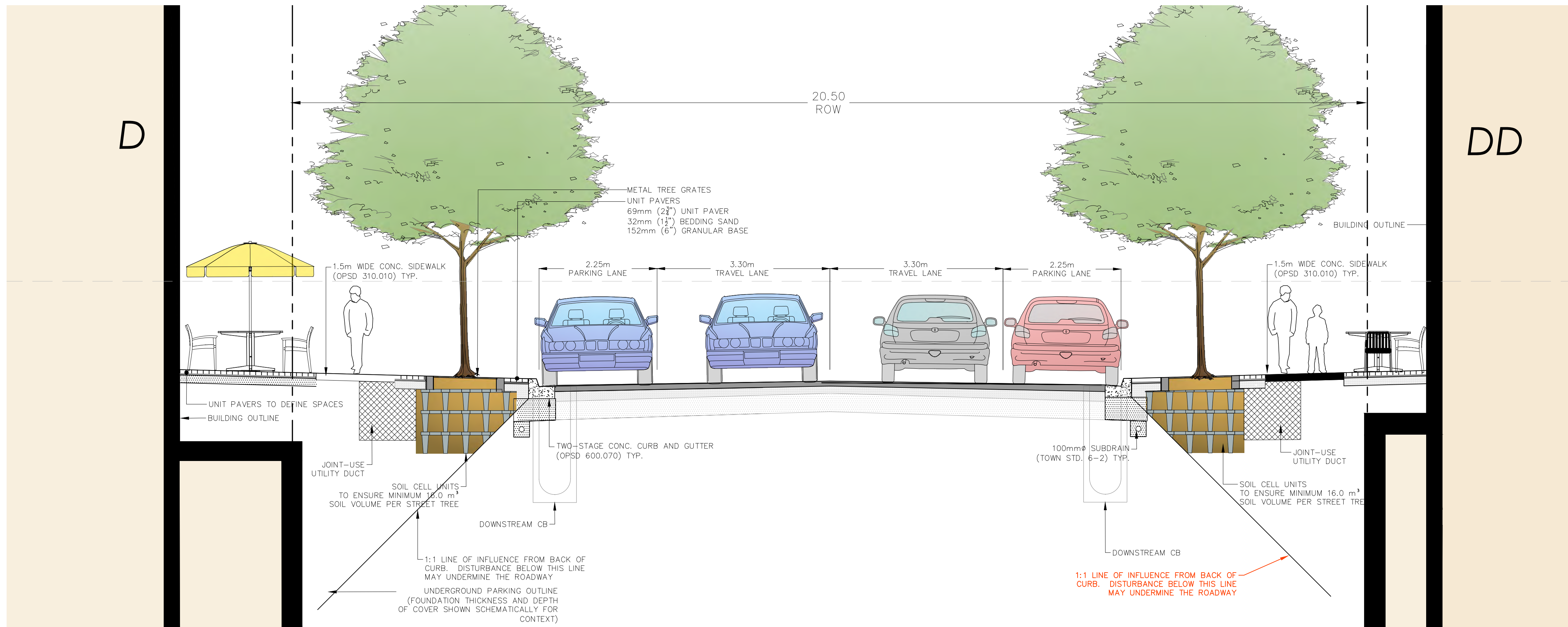

NOT FOR CONSTRUCTION  
ISSUED FOR REVIEW & COMMENTS ONLY

REVISIONS/ SUBMISSIONS

#	DATE	DESCRIPTION
1	2024-12-02	Issued for OPA/ZBA 1

STAMP



CLIENT  
Neatt Communities  
MUNICIPALITY  
Oakville

PROJECT  
3056 Neyagawa Boulevard  
Oakville, ON

MUNICIPAL FILE NUMBER

SHEET  
SECTION D

L-15

adesso design inc.  
landscape architecture

69 John Street South, Suite 250  
Hamilton, ON L8N 2B9  
t. 905.526.8876  
www.adessodesigninc.ca



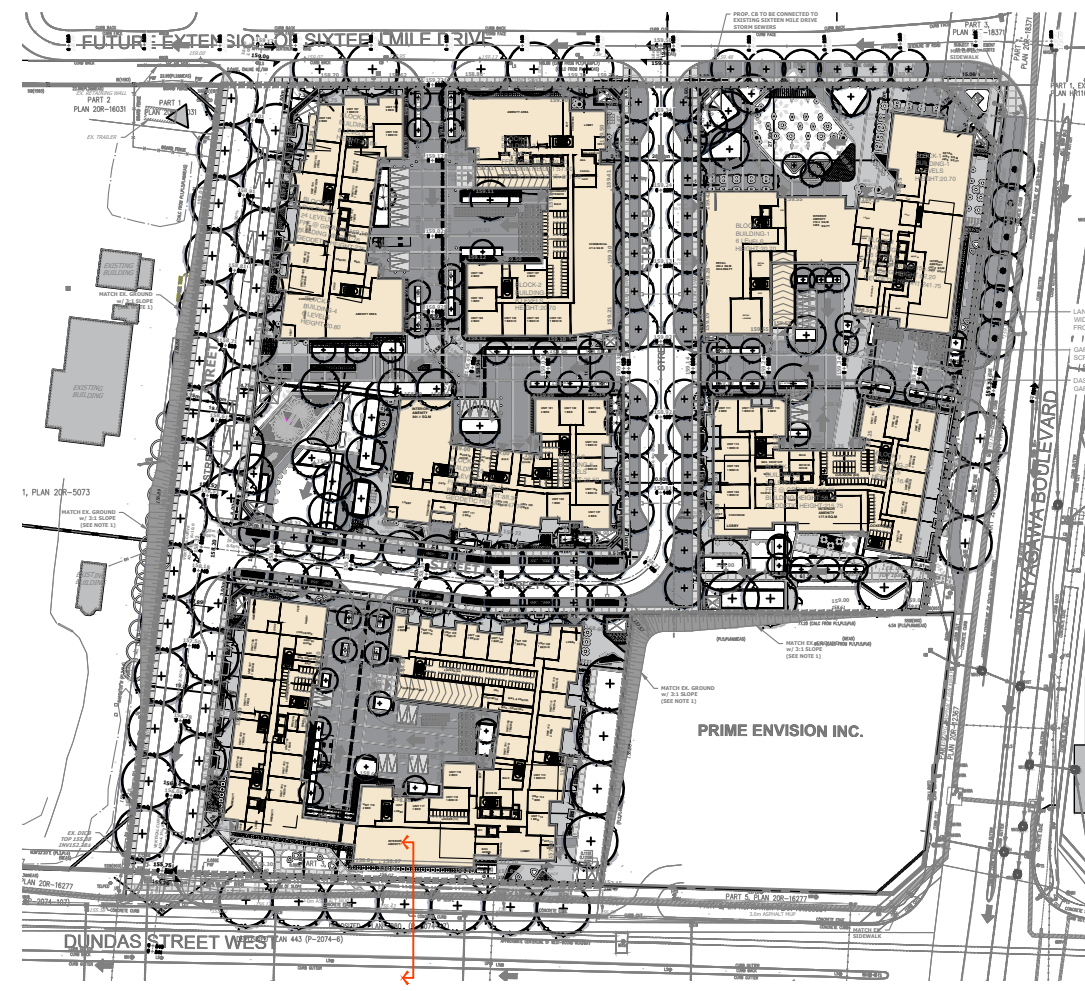

KEY MAP  
SCALE N.T.S.

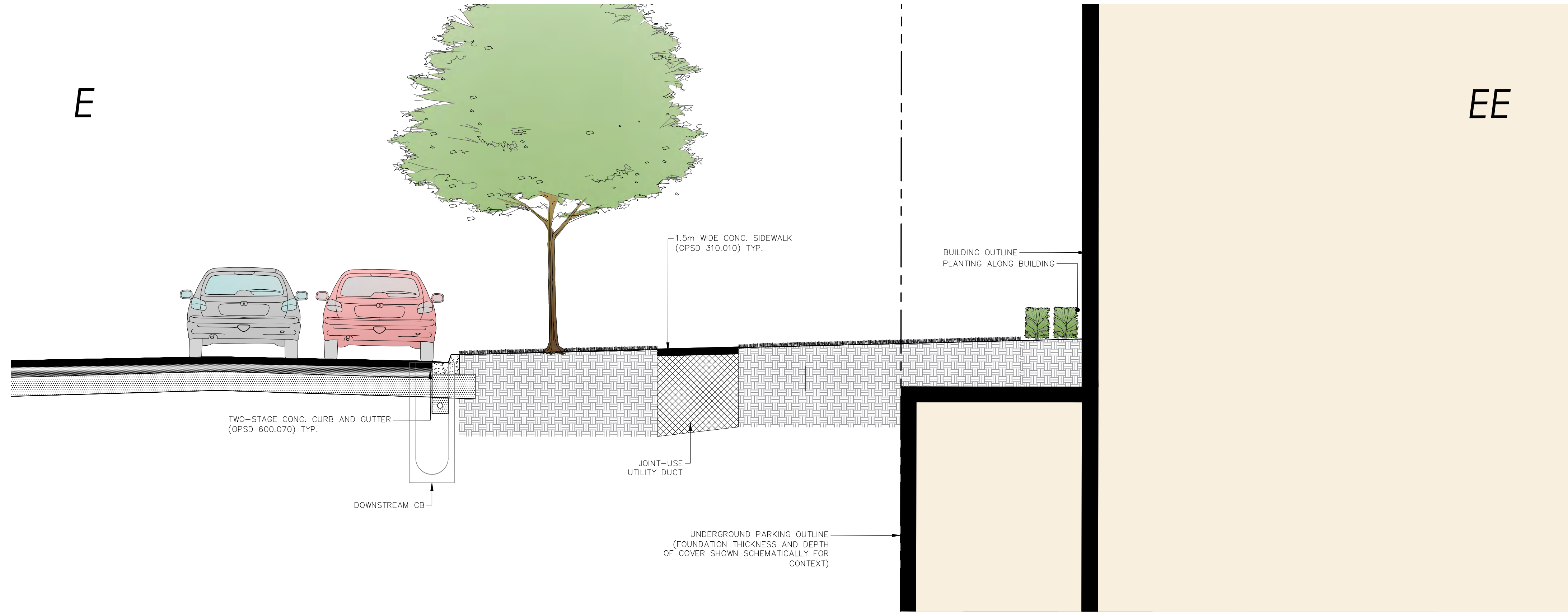
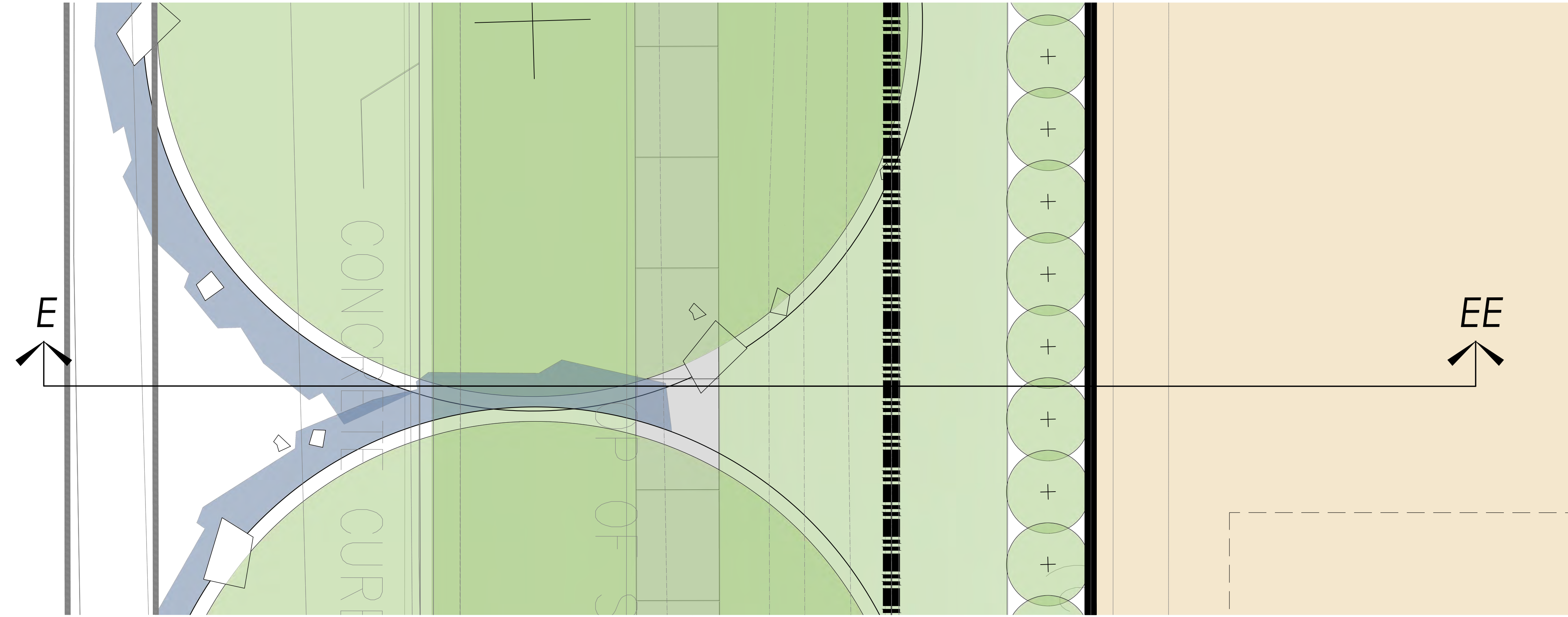

KEY MAP - N.T.S.



LEGEND

- property line
- existing tree to remain
- proposed deciduous tree
- proposed shrub
- proposed perennial
- min. 150mm topsoil, fine grade & sod
- C.I.P. concrete
- precast concrete unit pavers
- proposed light standard

**NOT FOR CONSTRUCTION**  
ISSUED FOR REVIEW & COMMENTS ONLY

#	DATE	DESCRIPTION
1	2024-12-02	Issued for OPA/ZBA 1

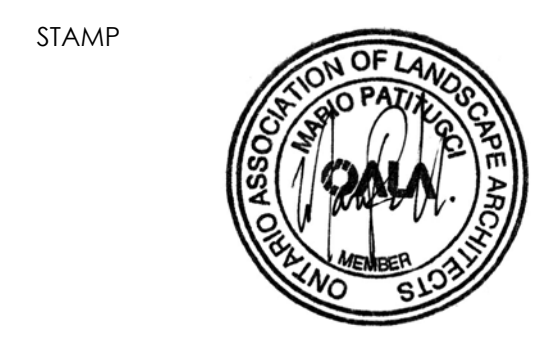

CLIENT  
**Neatt Communities**

MUNICIPALITY  
**Oakville**

PROJECT  
**3056 Neyagawa Boulevard  
Oakville, ON**

MUNICIPAL FILE NUMBER

SHEET  
Section E

L-16

**adesso design inc.**  
landscape architecture

 69 John Street South, Suite 250  
Hamilton, ON L8N 2B9  
t. 905.526.8876  
www.adessodesigninc.ca

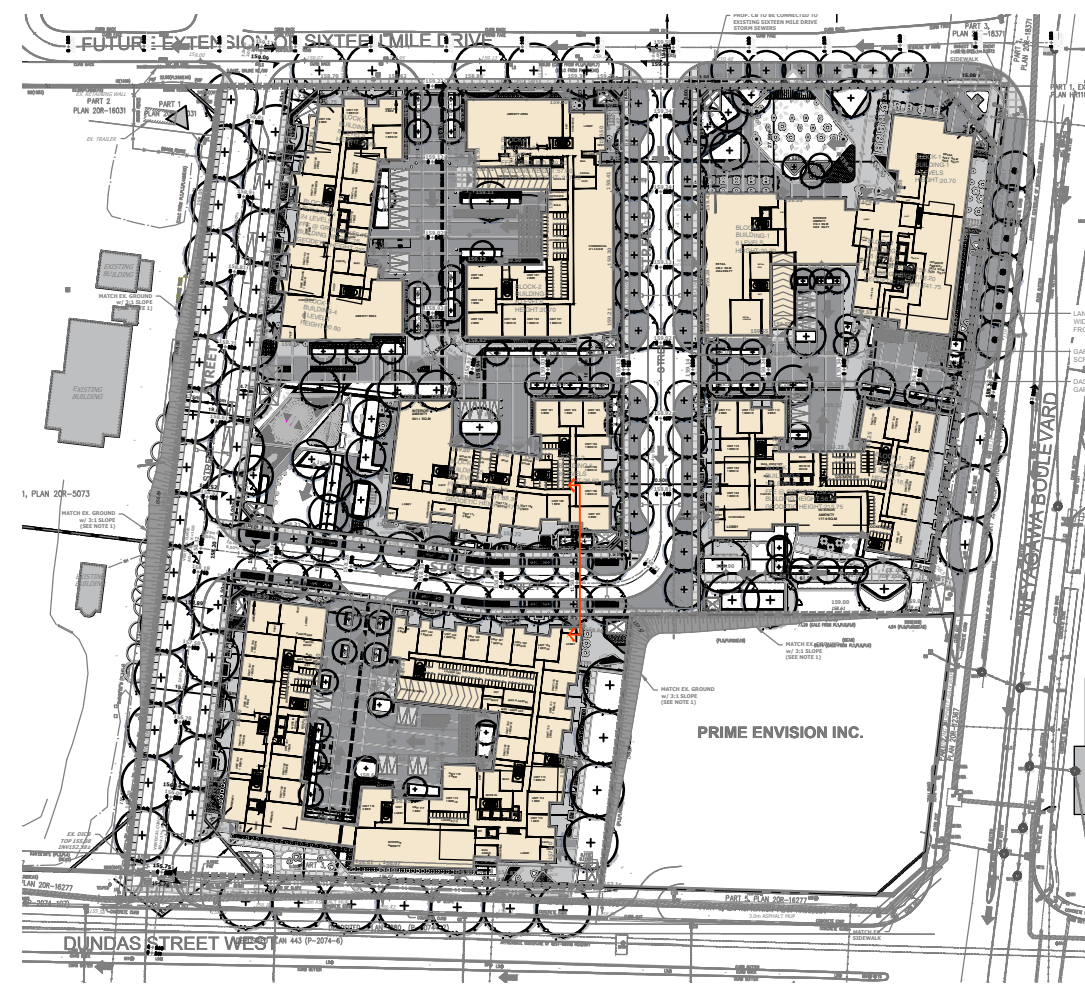

KEY MAP  
SCALE 1:500

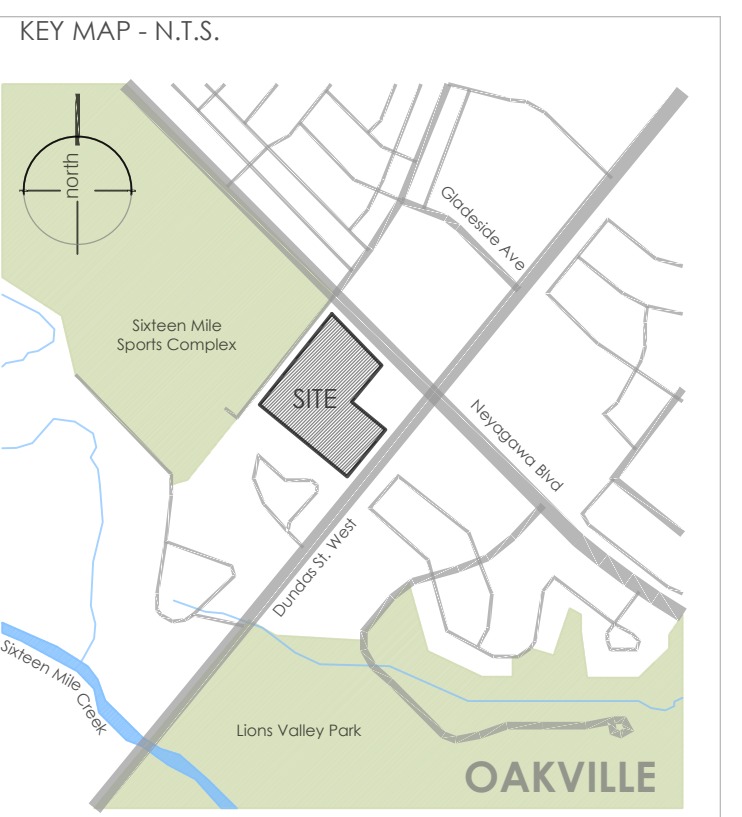
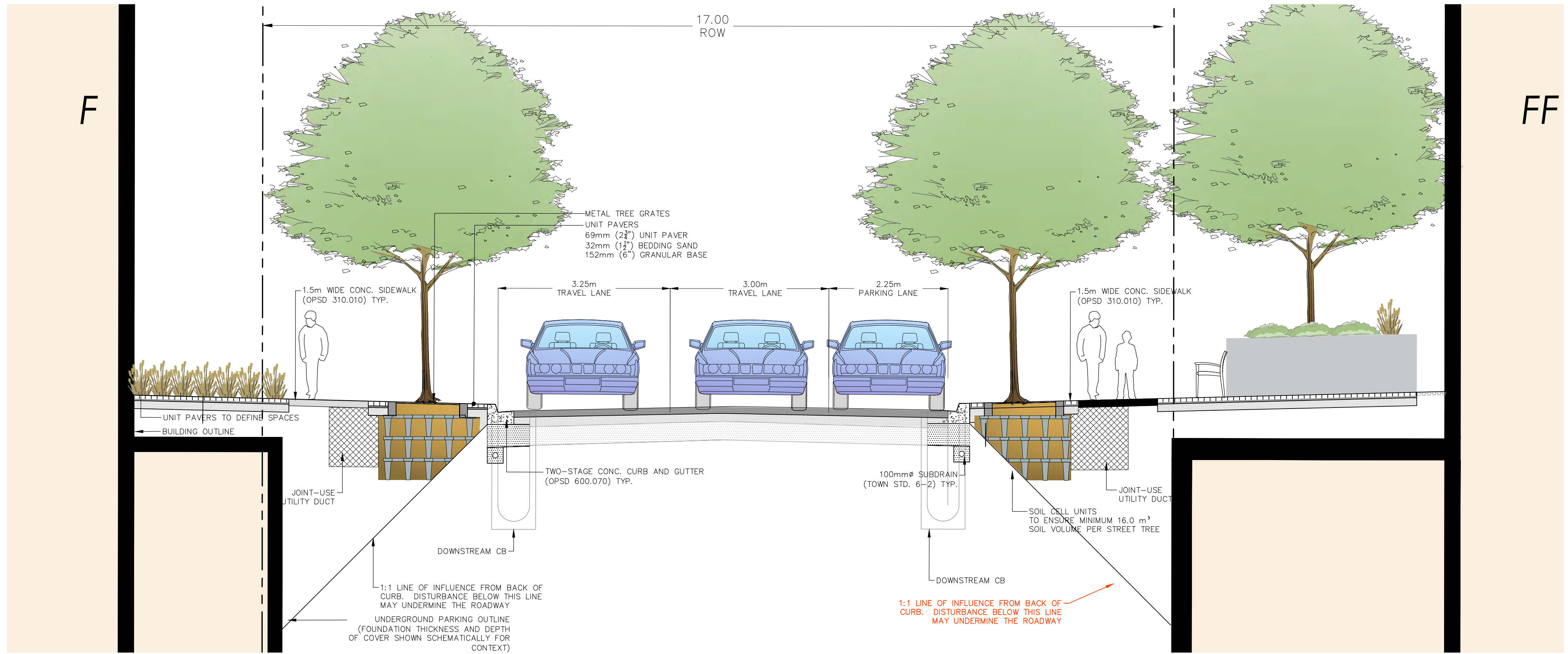
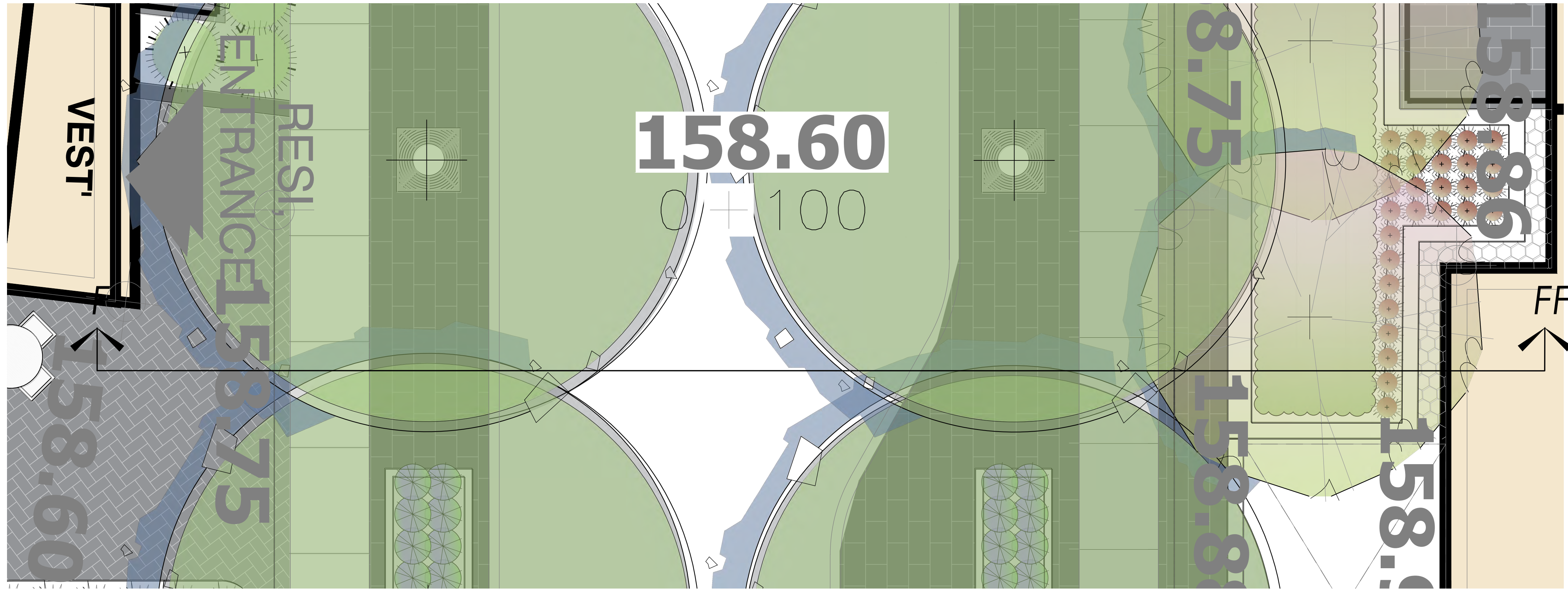

- LEGEND
- property line
  - existing tree to remain
  - proposed deciduous tree
  - proposed shrub
  - proposed perennial
  - min. 150mm topsoil, fine grade & sod
  - C.I.P., concrete
  - precast concrete unit pavers
  - proposed light standard

NOT FOR CONSTRUCTION  
ISSUED FOR REVIEW & COMMENTS ONLY

REVISIONS/ SUBMISSIONS

#	DATE	DESCRIPTION
1	2024-12-02	Issued for CPA/ZBA 1



CLIENT  
Neatt Communities

MUNICIPALITY  
Oakville

PROJECT  
3056 Neyagawa Boulevard  
Oakville, ON

MUNICIPAL FILE NUMBER

SHEET Section F  
L-17

adesso design inc.  
landscape architecture

69 John Street South, Suite 250  
Hamilton, ON L8N 2B9  
t. 905.526.8876  
www.adessodesigninc.ca



NOT FOR CONSTRUCTION  
ISSUED FOR REVIEW & COMMENTS ONLY

#	DATE	DESCRIPTION
1	2024-12-02	Issued for OPA/ZBA 1



CLIENT  
Neatt Communities

MUNICIPALITY  
Oakville

PROJECT  
3056 Neyagawa Boulevard  
Oakville, ON

MUNICIPAL FILE NUMBER

SHEET  
Circulation Plan

L-18

adesso design inc.  
landscape architecture

69 John Street South, Suite 250  
Hamilton, ON L8N 2B9  
1.905.526.8876  
www.adessodesigninc.ca