

REGISTERED PLAN No. M-2
PART OF BLOCK 7
PLAN 20M-492, PART 1
TOWN OF OAKVILLE
REGIONAL MUNICIPALITY OF HALTON

OWNERS	APPLICANT
DELAMERE ENTERPRISES INC. 2285 DUNWIN DRIVE, UNIT 3, MISSISSAUGA ON L5L 3S3 P (416) 305-4217 F (905) 812-7367	REINDERS + LAW LTD. 64 ONTARIO STREET NORTH, MILTON ON L9T 2T1 P (905) 457-1616

LEGEND:

- PROPERTY LINE
- BUILDING SETBACK LINE
- LANDSCAPE SETBACK LINE
- PROPOSED TREE PROTECTION HOARDING
- PROPOSED SILT FENCE
- PROPOSED FIRE ROUTE (USING HEAVY DUTY PAVING)
- HEAVY DUTY PAVING
- LIGHT DUTY PAVING
- CONCRETE PAD OR SIDEWALK OPSD 310.110
- PROPOSED CONCRETE CURB OPSD 800.110
- PROPOSED CONCRETE CURB WITH DEPRESSED CURB OPSD 310.033
- DIC
- NEW BUILDING AREA (FOOTPRINT)
- EXISTING BUILDING AREA (FOOTPRINT)
- EXISTING CHAIN LINK FENCE
- PROPOSED CHAIN LINK FENCE
- EXISTING POST AND WIRE FENCE
- PROPOSED POST AND WIRE FENCE
- EXISTING BOARD FENCE
- PROPOSED BOARD FENCE
- PRINCIPAL ENTRANCE TO THE BUILDING
- SECONDARY ENTRANCES TO, OR EGRESSES FROM THE BUILDING
- FIRE ROUTE SIGNS
- BARRIER FREE SIGNS (RB93)
- BARRIER FREE LOGO (PAVED ON ASPHALT)
- TACTILE STRIPS ON CONCRETE (AODA COMPLIANT) OPSD 310.039
- STOP SIGNS
- EXISTING CATCHBASIN AND STRUCTURE
- PROPOSED CATCHBASIN AND STRUCTURE
- PROPOSED DOUBLE CATCHBASIN AND STRUCTURE
- EXISTING MANHOLE
- PROPOSED MANHOLE
- EXISTING CATCHBASIN AND MANHOLE
- PROPOSED CATCHBASIN AND MANHOLE
- PROPOSED SIAMENSE CONNECTION TO SPRINKLER SYSTEM
- GAS METER
- PROPOSED HIGH POINT
- PROPOSED LOW POINT
- PROPOSED DRAINAGE FLOW
- DAYLIGHTING TRIANGLE (SHADED)
- DEPRESSED CURB
- FIRE HYDRANT (EXISTING) (REL = RELOCATED)

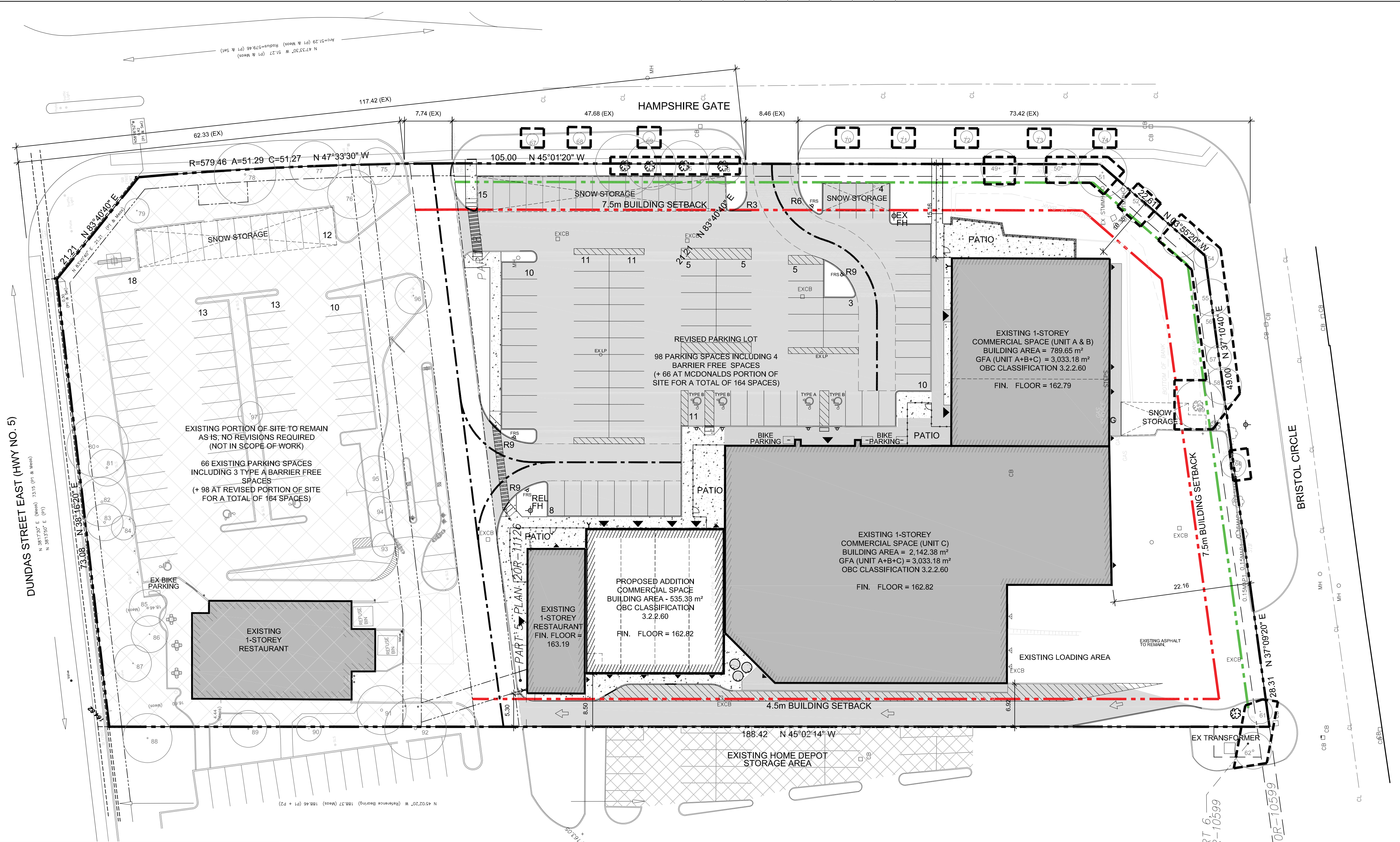
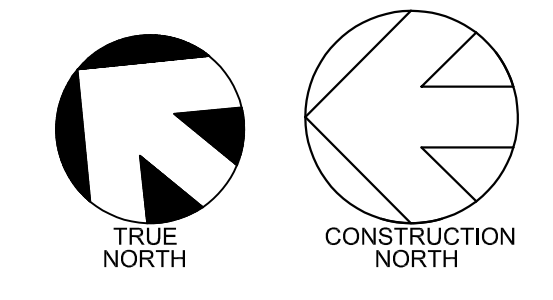

ZONING STATISTICS

ITEM	EXISTING ZONING BY-LAW REQUIREMENTS	PROPOSAL
ZONING CATEGORY	C3, SP-44	C3, SP-44
LOT AREA (sqm)	3,000	16,815.14
LOT WIDTH (m)	N/A	18.5
GROUND FLOOR AREA (sqm)	4,122.85	18.5
LOT COVERAGE (max)	14.5%	8,664.8 (50.3%)
ASPHALT AREA	1,122.44	1,305.44 (7.8)
WALKWAYS & CURBS AREA	1,122.44	1,305.44 (7.8)
LANDSCAPE AREA	2,937.55 (17.5%)	15m (EX)
FRONT YD. (min.) - BRISTOL CIRCLE	7.5m	10.5m (EX)
REAR YARD (min.) - DUNDAS ST. E.	15m	15.5m (EX)
EXT. SIDE YARD (min.)	7.5m	4.5m (EX)
SIDE YARD (min.)	4.5m	4.5m (EX)
NUMBER OF PARKING SPACES	132	164
NUMBER OF TYPE A ACCESSIBLE PARKING SPACES	3	4 (EXISTING)
NUMBER OF TYPE B ACCESSIBLE PARKING SPACES	3	3 (PROPOSED)
PARKING STALL DIMENSIONS (m)	2.7 x 5.7	2.7 x 5.7
TYPE A ACCESSIBLE PARKING SPACE (m)	3.65 x 5.7	3.65 x 5.7
TYPE B ACCESSIBLE PARKING SPACE (m)	2.7 x 5.7	2.7 x 5.7
ACCESSIBLE PARKING TABLE (m)	1.5	1.5
LOADING SPACE DIMENSIONS (m)	3.5 x 12.0	3.5 x 12.0
BICYCLE PARKING	5	6 NEW / 4 EX
SNOW STORAGE (sqm)	15% HARD SURFACE	534.2
GFA - EXISTING (sqm)		3,033.18
GFA - ADDITION (sqm)		535.38

no.	revisions	date	init.
4	RE-ISSUED FOR SPA (V3)	2024/09/13	KR
3	RE-ISSUED FOR SPA (V2)	2024/03/20	KR
2	ISSUED FOR SPA	2023/11/23	KR
1	ISSUED FOR CLIENT REVIEW	2023/08/01	KR
0	ISSUED FOR PRE CONSULTATION	2023/04/28	KR

GENERAL NOTE:
THESE DRAWINGS ARE COPYRIGHT AND THE PROPERTY OF REINDERS + LAW LTD. THE DRAWINGS MAY NOT BE USED FOR CONSTRUCTION WITHOUT THE PERMISSION OF REINDERS + LAW LTD. AND UNLESS SEALED AND SIGNED BY THE ARCHITECT/ENGINEER REPRODUCTION OF THESE DRAWINGS WITHOUT THE CONSENT OF REINDERS + LAW LTD. IS STRICTLY PROHIBITED.
DO NOT SCALE THESE DRAWINGS. ANY ERROR OR DISCREPANCY IS TO BE REPORTED IMMEDIATELY TO: REINDERS + LAW LTD.

cad file 23006_SP1-SP3
date plotted 2024/09/13 plot scale 1:1



drawn JY
designed JBH
reviewed KR
date 2024/09/13
scale 1:350

project
COMMERCIAL ADDITION

2500 HAMPSHIRE GATE
OAKVILLE, ONTARIO

drawing
OVERALL SITE PLAN

SP.1401.069/01
VERSION 3

REINDERS + LAW
ARCHITECTURE . ENGINEERING
REINDERS + LAW LTD.
ARCHITECTURE . ENGINEERING
64 ONTARIO STREET NORTH
MILTON, ON L9T 2T1
T. 905.457.1618 F. 905.457.8852
EMAIL@REINDERS.CA WWW.REINDERS.CA

drawing no. 23006_SP1 rev. no. 4

MBR-0100-00003
Legacy # MBR100-S

Sustainability Facts

Max Size One (1) MBR-0100-00003 Bike Rack

Carbon footprint (CO₂e) 61.3 kg CO₂-Eq

Total energy use (TPE) 1050 MJ-Eq

Water use (WUP) 0.527 m³ water

Material recyclability 100%

LEED v4.1 Credits

Type III Environmental Product Declaration

Material Innovation

Low VOC finishes

Free of Red List substances

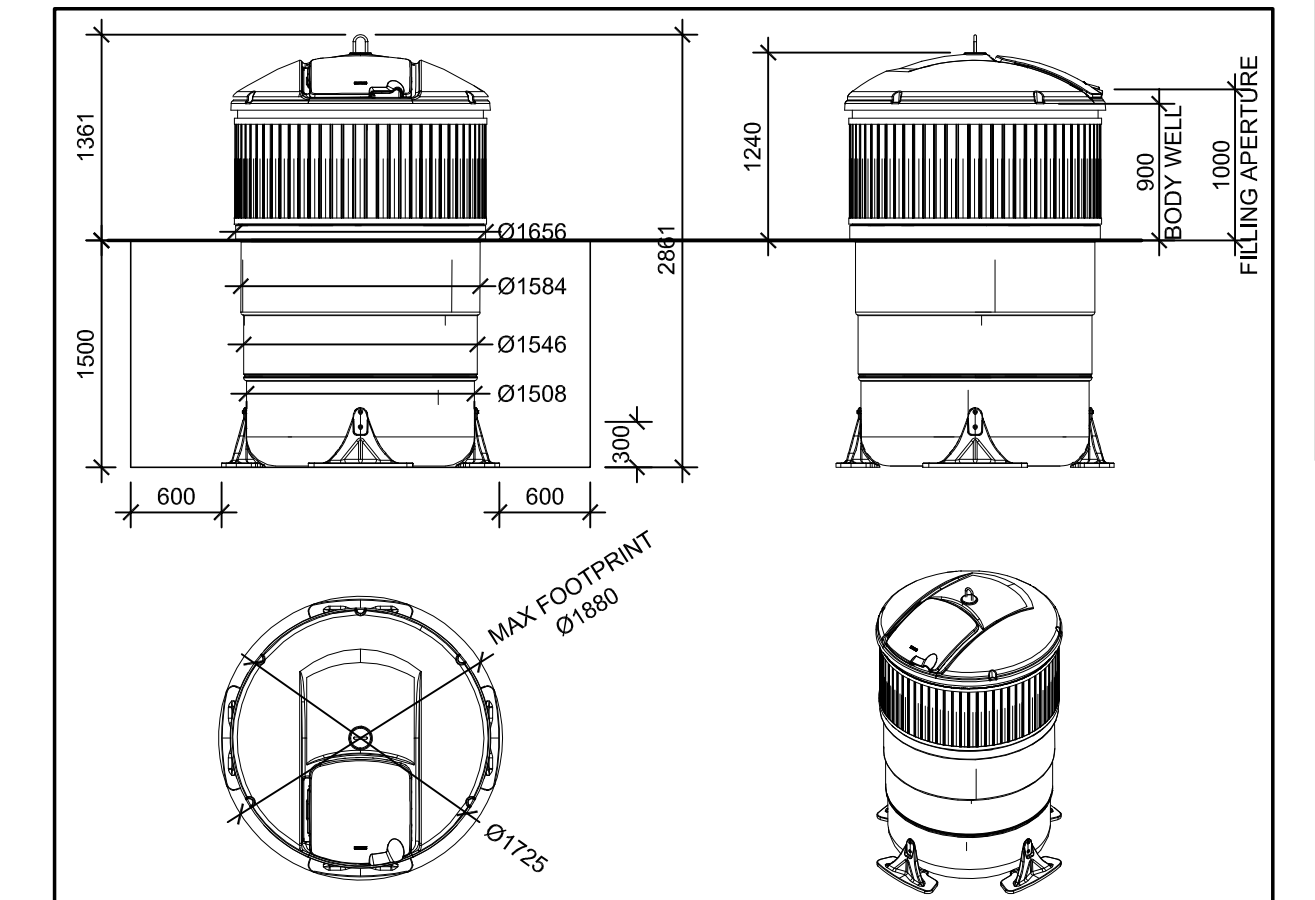
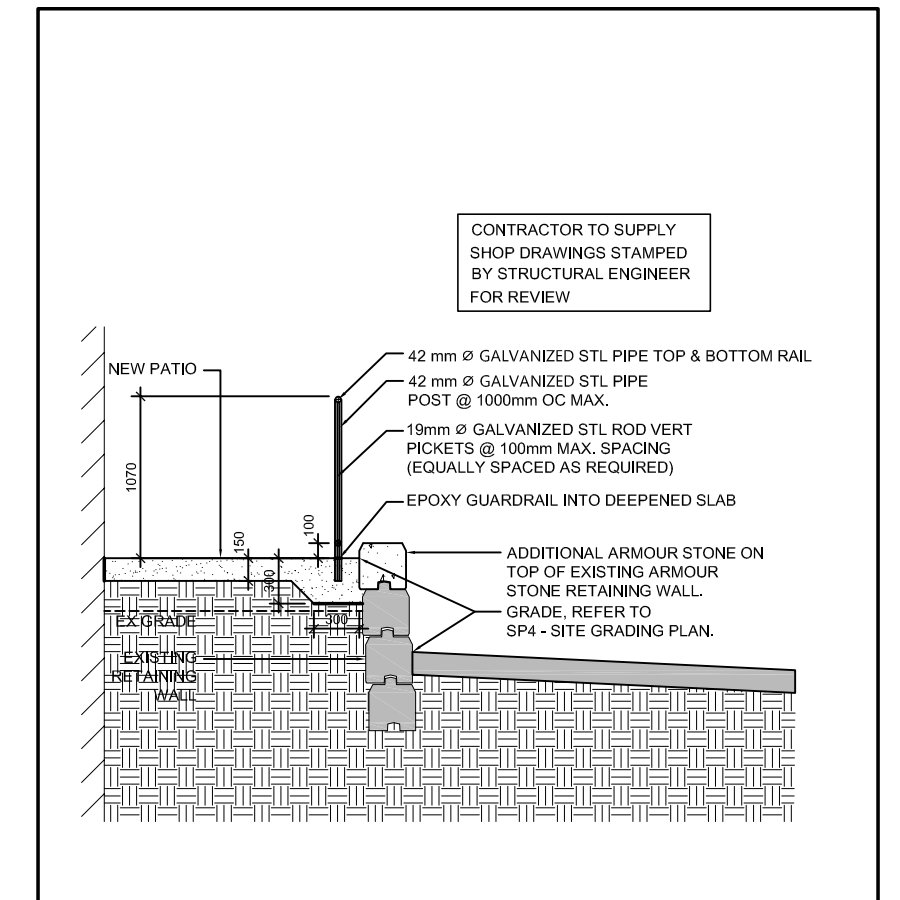
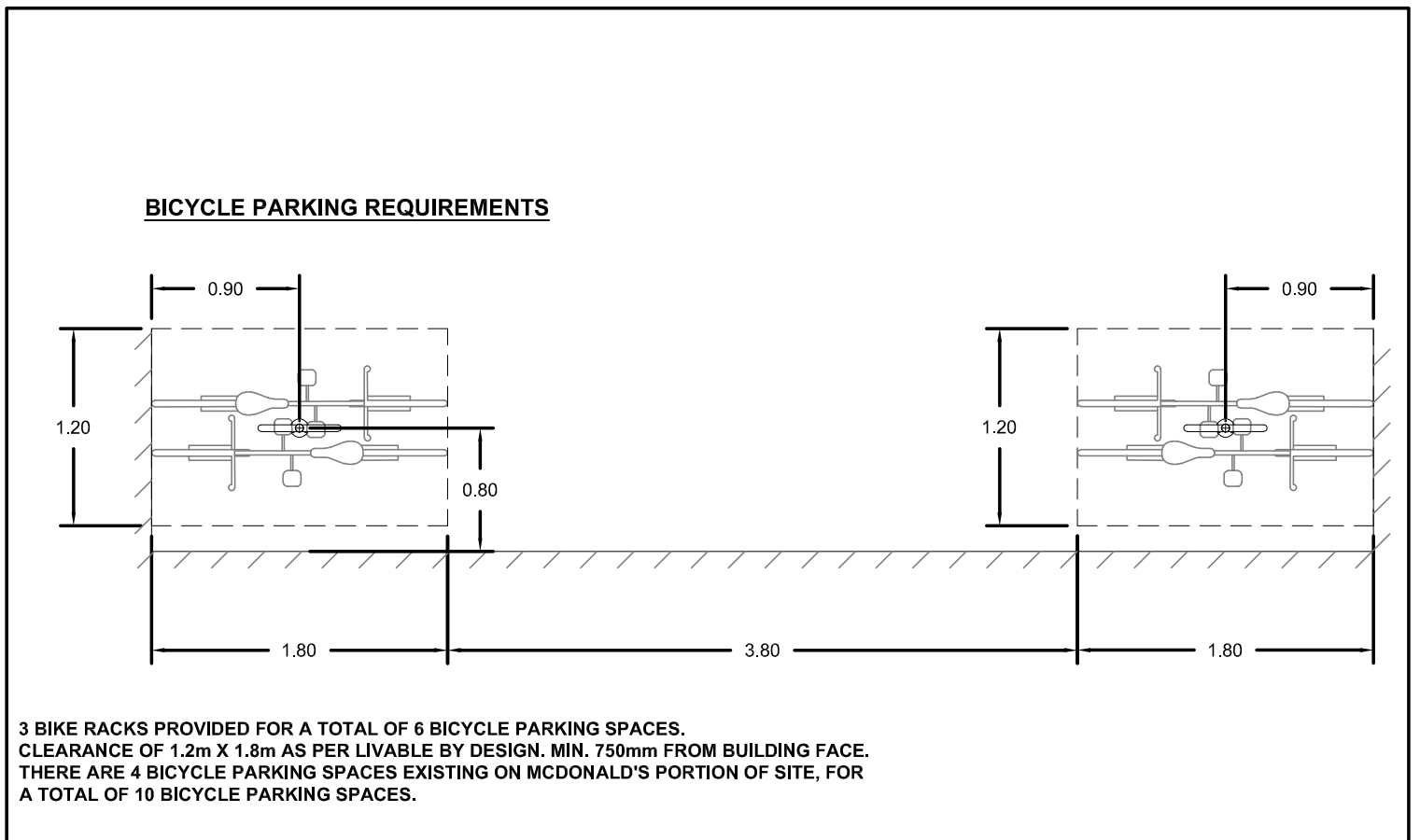
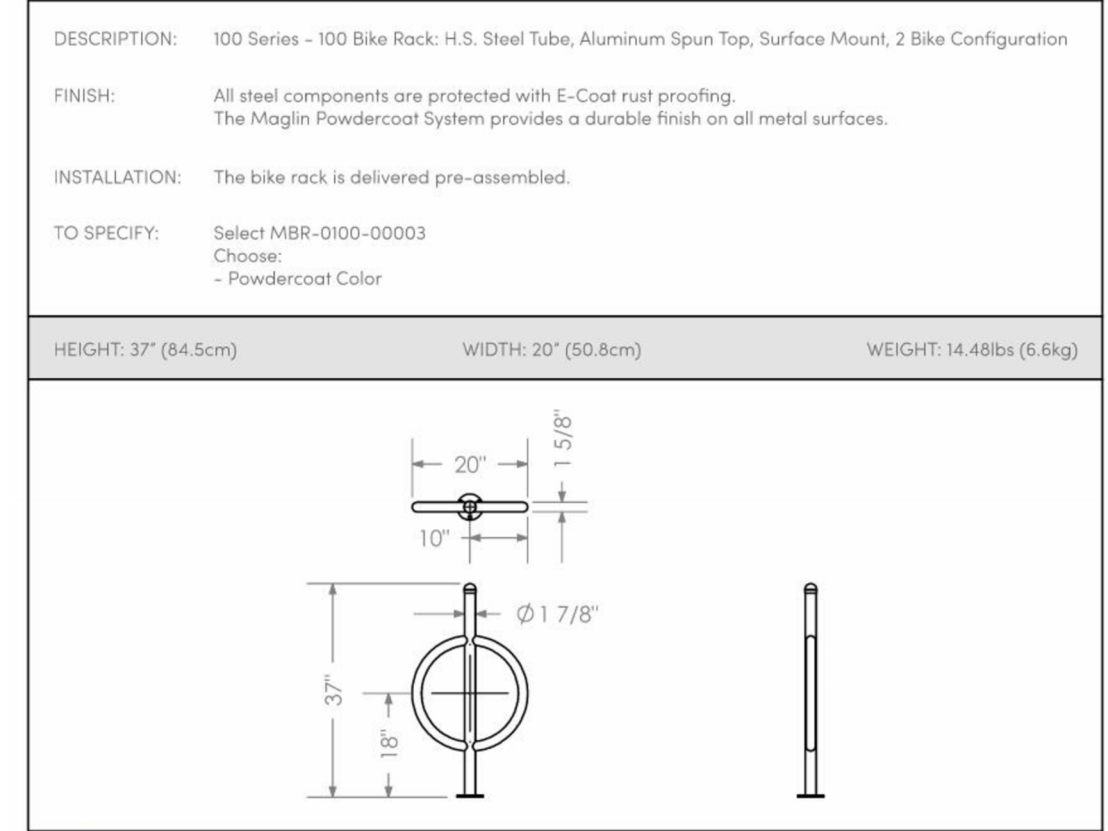

SHEET SIZE: A1 800.0mm X 914.4mm